

# **EMBERTON<sup>TM</sup>**

**ELECTRICAL APPLIANCES**

**PRODUCT CATALOGUE 2024**



# EMBERTON™

*Established 1986*

## *EMBERTON. INVEST FOR YOUR GUEST*

*“Investing in electrical engineering & technology to improve the safety, reliability & performance of electrical appliances worldwide”*

Safety, robustness and reliability are built into all of our professional range of guest room products. Emberton products are a solid investment, adding value to your assets.

With 35 years of history - design, innovation & creativity is our passion and the very heart of Emberton.

Working closely with a panel of experienced hoteliers helps us to understand the trends, habits & behavior of guests, perfecting our product innovations all the way from development to production.

Emberton products are available through a global network of specialist hotel supply distributors, with professional support and service to match the expectation of the Emberton brand.





**DUAL SAFE™, AN EMBERTON PROPRIETARY ELECTRICAL SAFETY SYSTEM, IS INTEGRATED INTO THE ELECTRICAL CIRCUIT TO DETECT TEMPERATURE**

**DUAL SAFE™ THERMOFUSE TECHNOLOGY** **WHAT DOES IT DO?**

DUAL SAFE™ prevents electrical appliances catching fire due to overheating.

**DUAL SAFE™ THERMOFUSE TECHNOLOGY** **HOW DOES IT WORK?**

DUAL SAFE™ uses an organic, thermo-sensitive material, remarkably sensitive to abnormally high temperatures. Upon sensing critical heat levels, DUAL SAFE™ activates and the electrical current will be interrupted immediately and permanently.

Working independently from and in addition to the thermostat, DUAL SAFE™ system immediately cuts power to an appliance when temperatures reach critical levels.

**DUAL SAFE™ THERMOFUSE TECHNOLOGY** **WHAT DOES IT DO?**

In most electrical appliances, the thermostat is the only safety system. Thermostats are very sensitive components and can become faulty or damaged by misuse. If the thermostat fails, it's easy for the appliance to catch fire.

DUAL SAFE™ acts as an additional safety system, preventing risk of an accidental fire when using an EMBERTON DUAL SAFE™ electrical appliance.

# INDEX

## KETTLES 05-11

Evesham  
Malvern  
Corsham  
Banbury  
Guildford



KETTLES

## BAMBOO WELCOME TRAYS 12-22

Fenland  
Winford  
Amesbury  
Cambourne Plus  
Tongwell



WELCOME TRAYS  
BAMBOO

## WELCOME TRAYS 23-30

Heywood Slate ABS  
Walton ABS  
Andover ABS  
Mere (Adaptor)  
Halstead



WELCOME TRAYS

## HAIRDRYERS 31-38

Thames  
Harrow  
Emsworth  
Ashford  
Devizes (Hairdryer Holder)  
Mursley (Hairdryer Holder)  
Lathbury (Hairdryer Bag)



HAIRDRYERS

## IRONS 39-45

Croft Deluxe  
Hertford  
Yardley  
Amphill  
Cheshunt  
Steamer & Iron Bag



IRONS

## TOUGH IRONING BOARDS 46-47

Rothwell  
Moulton  
Sherington



TOUGH IRONING  
BOARDS

## IRONING CENTRES SAFETY & STORAGE 48-55

Bromham  
Kingsmead  
Elstow  
Stagsden  
Stroud  
Somerton  
Oakham  
Crawley  
Sandhurst (Holder)  
Hyde (Holder)



IRONING CENTRES  
SAFETY & STORAGE

## MINIBAR & GUEST SAFE BOX 56-64

Chesham  
Brixham  
Penzance  
Redditch  
Kendal  
Romney  
Derby  
Dewsbury  
Witney



MINIBAR & GUEST  
SAFE BOX

## ACCESSORIES & ROOM ESSENTIALS 65-74

Bodmin Multi-Function Alarm Clock  
Alton USB Rechargeable Torchlight  
Woburn Push Power Bathroom Scale  
Whitehill Scale  
Wilton Scale (Bamboo)  
Fairford Bathroom Scale  
Ashton Bathroom Scale



ACCESSORIES &  
ROOM ESSENTIALS

## SERIES - A 75-76

1600W Cylindrical Hairdryer  
Emergency Torchlight INSTANT-ON



SERIES - A

## SPECIFICATIONS 77-88

Technical Data  
Dimensions  
Packaging Details



SPECIFICATIONS





## KETTLES

### Evesham

#### Double Wall Safety Insulated Kettle 1.0L

- ➔ Boil Aware 360 : active BLUE boil-on LED pilot ALERT light encircles complete body with 360° glow for added safety awareness during boiling
- ➔ Double Layer Safety Insulation - reduces surface heat to help prevent scalding & heat loss
- ➔ Illuminated Water window - clear and brightly lit blue LED for greater clarity of water level
- ➔ Advanced Technology Isolation Boil Dry
- ➔ Dual Safe – Thermostat & Latest Technology Internal Fuse
- ➔ High Grade SS304 Stainless Steel Body & Heat Plate
- ➔ ECO saves Water and Energy
- ➔ Concealed Heating Element for Easy Cleaning
- ➔ Auto Steam Switch off
- ➔ Auto Off Power Indicator Light
- ➔ Hinged Trigger Style Locking lid
- ➔ Available in EU & BS plug variants

#### Specifications

Power	1500-1800W (220-240V, 50-60Hz)
Dimensions	220 x 143 x 220mm
Overall Height	220mm
Top Diameter	88mm
Base Diameter	143mm
Certification	CE, CB, RoHS & GS Approved
Weight	930g



Double Layer Safety Insulation



360° Swivel



Registered Design



Design Protected by  
International Registered Designs  
& Patents Pending  
© Emberton Group Inc



Available in BLACK

# Evesham

Double Wall Safety Insulated Kettle 1.0L



Available in BLACK

## Malvern Brushed Stainless Steel Kettle 0.5L

- ➔ Advanced Technology Isolation Boil Dry
- ➔ Dual Safe – Thermostat & Latest Technology Internal Fuse
- ➔ Water Level Gauge Window
- ➔ ECO saves Water and Energy
- ➔ Concealed Heating Element for Easy Cleaning
- ➔ Auto Steam Switch off
- ➔ Auto Off Power Indicator Light
- ➔ Hinged Trigger Style Locking lid
- ➔ Available in EU & BS plug variants

### Specifications

Power	800-950 Watt (220-240V, 50-60Hz)
Dimensions	190 x 150 x 185mm
Overall Height	185mm
Top Diameter	90mm
Base Diameter	143mm
Certification	CE, CB, RoHS & UKCA Approved
Weight	770g



High Grade SS304  
Stainless Steel Body  
& Heat Plate



Cordless 360° Swivel



Registered Design



Design Protected by  
International Registered Designs  
& Patents Pending  
© Emberton Group Inc



Available in BLACK

## Corsham

### Brushed Stainless Steel Kettle 1.0L

- Advanced Technology Isolation Boil Dry
- Dual Safe – Thermostat & Latest Technology Internal Fuse
- Water Level Gauge Window
- ECO saves Water and Energy
- Concealed Heating Element for Easy Cleaning
- Auto Steam Switch off
- Auto Off Power Indicator Light
- Hinged Trigger Style Locking lid
- Available in EU & BS plug variants

#### Specifications

Power	800-950 Watt (220-240V, 50-60Hz)
Dimensions	190 x 143 x 209mm
Overall Height	209mm
Top Diameter	90mm
Base Diameter	143mm
Certification	CE, CB, RoHS & UKCA Approved
Weight	790g



High Grade SS304 Stainless Steel Body & Heat Plate



Cordless 360° Swivel



Registered Design



Design Protected by  
International Registered Designs  
& Patents Pending  
© Emberton Group Inc





## Banbury

### SEAMLESS Double Wall Safety Insulated Kettle 0.8L

- ➔ Highest Quality & Sturdy Body & Lid
- ➔ Only 800W Power Consumption Average
- ➔ Advance Technology Isolation Boil Dry
- ➔ Dual Safe - Thermostat & Latest Technology Internal Fuse
- ➔ High Grade SS304 Stainless Steel Body & Heat Plate
- ➔ ECO saves Water and Energy
- ➔ SEAMLESS Stainless Steel Interior & Concealed Heating Element for Easy Cleaning
- ➔ Auto Steam Switch Off
- ➔ Auto Off Power Indicator Light
- ➔ Hinged Trigger Style Locking Lid
- ➔ Available in EU & BS plug variants

#### Specifications

Power	<b>800W (220-240V, 50-60Hz)</b>
Dimensions	<b>190 x 130 x 200mm</b>
Overall Height	<b>200mm</b>
Top Diameter	<b>111.5mm</b>
Base Diameter	<b>130mm</b>
Certification	<b>CE, CB, UKCA &amp; RoHS Approved</b>
Weight	<b>750g</b>



No Welds - Easy Clean SEAMLESS SS304 Steel Body & Heat Plate



360° Swivel Cordless



Hinged Trigger Style Locking Lid





## Guildford Premium Hotel Kettle 0.8L

- ➔ Only 950W Power Consumption Average
- ➔ Advanced Technology Isolation Boil Dry – 100% OFF Non-Recycle
- ➔ SS 304 Stainless Steel Heat Boiling Plate
- ➔ Water Level Gauge Window
- ➔ Durable Trigger Style Spring Assisted Locking Lid
- ➔ Easy Water Pour & Flow
- ➔ Easy Wipe Clean Plastic Interior
- ➔ Concealed Heating Element for Easy Cleaning
- ➔ Auto Steam Switch off
- ➔ Auto Off Power Indicator Light
- ➔ Washable Filter

### Specifications

Power	870 - 1035W (220-240V, 50-60Hz)
Dimensions	187 x 139 x 180mm
Overall Height	180mm
Top Diameter	90mm
Base Diameter	139mm
Certification	CE, CB & UKCA Approved
Weight	605g



SS 304  
Stainless Steel Base



360° Swivel Cordless



Highest Quality &  
Sturdy Body & Lid





Available in WHITE

**Guildford**  
Premium Hotel Kettle 0.8L





### 1. FASTEST GROWING PLANT IN THE WORLD

Bamboo is the world's fastest-growing plant, shooting out of the ground at an astonishing four centimetres per second. At this rate, certain bamboo species can grow 91 centimetres (about 35 inches) in a single day. A bamboo culm can be ready to re-harvest in a mere 3-5 years. Bamboo shoots are connected to their parent plant by an underground stem, called a rhizome. These rhizomatic cores are part of the reason why bamboo can grow so quickly.

### 2. DURABILITY AND SUSTAINABLE

Bamboo grows in dense forests where little light reaches the ground and there is strong evolutionary pressure to reach the sunlight as quickly as possible. Bamboo also plays an important role when it comes to protecting the soil and land around it; those long strong roots keep the soil together to prevent erosion.



### 3. ECO-FRIENDLY PRODUCTS

Bamboo is a climate-adaptable plant that can thrive in a number of different environments and has showcased remarkable resilience in the face of an impressive number of environmental stressors. Compared to an equivalent tree mass, bamboo produces 35% more oxygen and research has shown that bamboo can absorb as much as 12 tonnes of carbon dioxide per hectare per year. Bamboo can also be harvested without killing the plant's core that produces the collectible stalks, meaning that soil erosion is reduced throughout the harvesting process.

### 4. EROSION CONTROL AND SOIL PROTECTION

Bamboos are being used as living plants as well as construction material in different soil bioengineering techniques in many countries. Bamboo is a great tool for soil protection due to its rapid growth, permanent canopy and huge network of roots and rhizomes. The root system that grows in the surface layer of the soil (20 - 60 cm deep), can reach up to 100 km per hectare.



### 5. WATER CONSERVATION

Bamboo is a versatile and effective tool for water conservation efforts. It is increasingly used by environmental organisations and governments worldwide to help protect and conserve our precious water resources. Bamboo plants have a low water requirement and can grow in areas with limited water resources, helping to conserve water.



# NO to PVC & PU Fake Leather. Hello to Bamboo.....

Plastic, particularly PVC (polyvinyl chloride) and PU (polyurethane), is widely used in various industries and products. However, there are several reasons why we should reduce our reliance on and avoid using these types of plastic. Some of the main reasons include:



## 1. ENVIRONMENTAL IMPACT

PVC and PU production involves the use of fossil fuels and synthetic chemicals, which contribute to air pollution, water pollution and greenhouse gas emissions. Additionally, these plastics are not easily biodegradable and can persist in the environment for hundreds of years, leading to long-term harm to ecosystems.

## 2. TOXICITY CONCERNS

PVC contains additives such as phthalates, lead and heavy metals, which can leach out and pose risks to human health. Exposure to these toxins has been associated with various health issues, including respiratory problems, hormonal disruptions, developmental disorders and certain types of cancer.



## 3. WASTE GENERATION

PVC and PU, like most plastics, generate significant waste during their production, use and disposal phases. The improper disposal and incineration of these plastics release toxic by-products and pollutants into the environment, further exacerbating environmental and health concerns.

## 4. RECYCLING CHALLENGES

PVC and PU pose challenges in terms of recycling. These plastics have different chemical compositions and require specialized recycling processes, which are often limited and costly. As a result, a significant portion of PVC and PU waste ends up in landfills or incinerators rather than being recycled.



## 5. SUSTAINABLE ALTERNATIVES

There are many sustainable and eco-friendly alternatives to PVC and PU available in the market. For example, **BAMBOO PLANT IS AN EXCELLENT NATURAL ALTERNATIVE** IS MADE INTO TRAYS & FURNITURE. Natural fibers like cotton, hemp, or cork can be used as alternatives to PU in fashion and footwear industries. Recycled or bio-based plastics, such as PLA (polylactic acid), can serve as alternatives to PVC in packaging materials.



## Fenland Espresso Tray & Condiment Box

- ➔ Eco-Friendly First Grade Bamboo
- ➔ Certified Food Grade
- ➔ Robust & Sturdy Construction
- ➔ Stores Condiments Neatly & Dust Free
- ➔ Elegant Soft Contour Design
- ➔ Easy to Clean – Smooth Surface to Wipe Clean
- ➔ Neat and Tidy Condiments Presentation
- ➔ Designed to Fit Most Types of Compact Espresso Machines

### Specifications

	ESPRESSO TRAY	CONDIMENT BOX
Dimensions	50 x 40 x 4cm	19 x 21 x 7cm
Material	First Grade Bamboo	First Grade Bamboo
Weight	1.8kg	0.8kg



Fit Most Types of Compact Espresso Machines



ESPRESSO TRAY



CONDIMENT BOX



\* Tray & Condiment Box Only – Excludes Coffee Machine, kettle, Cups & Ingredients



## Winsford

### Espresso Coffee Welcome Tray with Protective Spillage Tray

- Eco-Friendly First Grade Bamboo
- Removable Tray Prevents Spillage & Protects Surface
- Elegant Soft Contour Design
- Stores Ingredients Neatly & Dust Free
- Drawer stores condiments 57mm high
- Certified Food Grade
- Robust & Sturdy Construction
- Easy to clean – smooth surface to wipe clean
- Neat & Tidy Condiments Presentation
- Easy Slide In & Out Multiple Compartments Drawer
- Drawer Stopper - Spring retaining clip prevents intentional removal of drawer
- Tray Only – Excludes Coffee Machine & Kettle
- Designed to fit most types of compact espresso machines

#### Specifications

Dimensions	370 mm x 350 mm x 88 mm
Material	First Grade Bamboo
Weight	3.75 kg



Fit Most Types of Compact Espresso Machines



Elegant SOFT CONTOUR Design



Space Saving Ultra-Compact



CERTIFIED  
FOOD  
GRADE



(Coffee Machine, Kettle, Cups & Ingredients NOT included)





## Amesbury Compact Espresso Drawer Tray

- ➔ Eco-Friendly First Grade Bamboo
- ➔ Certified Food Grade
- ➔ Robust & Sturdy Construction
- ➔ Stores Condiments Neatly & Dust Free
- ➔ Easy Slide In & Out Multiple Compartments Drawer - Removable Drawer for Easy Cleaning
- ➔ Elegant Soft Contour Design
- ➔ Easy to Clean – Smooth Surface to Wipe Clean
- ➔ Neat and Tidy Condiments Presentation
- ➔ Drawer Stopper – Spring Retaining Clip Prevents Intentional Removal of Drawer
- ➔ Large Drawer Tray with 4 compartments.
- ➔ Designed to Fit Most Types of Compact Espresso Machines

### Specifications

Dimensions	<b>W31.5 x D39.0 x H7.5 cm</b>
Material	<b>First Grade Bamboo</b>
Weight	<b>2.64kg</b>



Fit Most Types of Compact Espresso Machines



Elegant SOFT CONTOUR Design



Space Saving Ultra-Compact



(Coffee Machine, Kettle, Cups & Ingredients NOT included)





## Cambourne Plus

Drawer Welcome Tray with Protective Spillage Tray

- ➔ Eco-Friendly First Grade Bamboo
- ➔ Removable Tray Prevents Spillage & Protects Surface
- ➔ Elegant Soft Contour Design
- ➔ Stores Ingredients Neatly & Dust Free
- ➔ Drawer stores condiments 57mm high
- ➔ Certified Food Grade
- ➔ Robust & Sturdy Construction
- ➔ Easy to clean – smooth surface to wipe clean
- ➔ Neat & Tidy Condiments Presentation
- ➔ Easy Slide In & Out Multiple Compartments Drawer
- ➔ Designed to fit **EMBERTON™** Kettles

### Specifications

Dimensions	272mm x 194mm x 85mm
Material	First Grade Bamboo
Weight	1450g



Space Saving Ultra Compact



Removable Drawer for Easy Cleaning

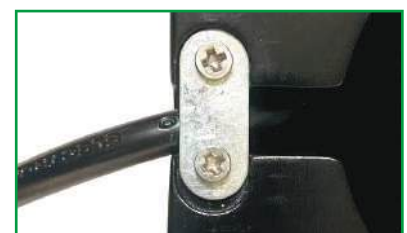

(Kettle, Cups & Ingredients not included)



CERTIFIED  
FOOD  
GRADE



CONDIMENTS  
STORE



1st GRADE  
BAMBOO





## Tongwell Bamboo Welcome Tray

- Eco Friendly Bamboo
- Integrated Kettle to Deter Theft
- Elegant and Compact Design
- Easy Wipe-Clean Curved Contour Edges
- First Grade Bamboo Material
- Space Saving, Modular Design
- Food Grade Safety
- Designed to fit **EMBERTON™** Kettles



### Specifications

Dimensions	260mm x 260mm x 30mm
Material	First Grade Bamboo
Weight	850g



CERTIFIED  
FOOD  
GRADE



DUST  
FREE  
CONDIMENTS  
STORE



1st GRADE  
BAMBOO



(Kettle, Cups & Ingredients not included)



## Winsford

### Espresso Coffee Welcome Tray with Protective Spillage Tray

- Eco-Friendly First Grade Bamboo
- Removable Tray Prevents Spillage & Protects Surface
- Elegant Soft Contour Design
- Stores Ingredients Neatly & Dust Free
- Drawer stores condiments 57mm high
- Certified Food Grade
- Robust & Sturdy Construction
- Easy to clean – smooth surface to wipe clean
- Neat & Tidy Condiments Presentation
- Easy Slide In & Out Multiple Compartments Drawer
- Drawer Stopper - Spring retaining clip prevents intentional removal of drawer
- Tray Only – Excludes Coffee Machine & Kettle
- Designed to fit most types of compact espresso machines

#### Specifications

Dimensions	370 mm x 350 mm x 88 mm
Material	First Grade Bamboo
Weight	3.75 kg



Fit Most Types of Compact Espresso Machines



Elegant SOFT CONTOUR Design

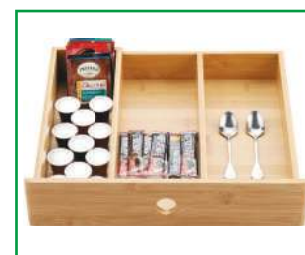

Space Saving Ultra-Compact



CERTIFIED  
FOOD  
GRADE



CONDIMENTS  
STORE



1st GRADE  
BAMBOO



(Coffee Machine, Kettle, Cups & Ingredients NOT included)





## Amesbury Compact Espresso Drawer Tray

- ➔ Eco-Friendly First Grade Bamboo
- ➔ Certified Food Grade
- ➔ Robust & Sturdy Construction
- ➔ Stores Condiments Neatly & Dust Free
- ➔ Easy Slide In & Out Multiple Compartments Drawer - Removable Drawer for Easy Cleaning
- ➔ Elegant Soft Contour Design
- ➔ Easy to Clean – Smooth Surface to Wipe Clean
- ➔ Neat and Tidy Condiments Presentation
- ➔ Drawer Stopper – Spring Retaining Clip Prevents Intentional Removal of Drawer
- ➔ Large Drawer Tray with 4 compartments.
- ➔ Designed to Fit Most Types of Compact Espresso Machines

### Specifications

Dimensions	<b>W31.5 x D39.0 x H7.5 cm</b>
Material	<b>First Grade Bamboo</b>
Weight	<b>2.64kg</b>



Fit Most Types of Compact Espresso Machines



Elegant SOFT CONTOUR Design



Space Saving Ultra-Compact



CERTIFIED  
FOOD  
GRADE



(Coffee Machine, Kettle, Cups & Ingredients NOT included)





## Cambourne Plus

### Drawer Welcome Tray with Protective Spillage Tray

- ➔ Eco-Friendly First Grade Bamboo
- ➔ Removable Tray Prevents Spillage & Protects Surface
- ➔ Elegant Soft Contour Design
- ➔ Stores Ingredients Neatly & Dust Free
- ➔ Drawer stores condiments 57mm high
- ➔ Certified Food Grade
- ➔ Robust & Sturdy Construction
- ➔ Easy to clean – smooth surface to wipe clean
- ➔ Neat & Tidy Condiments Presentation
- ➔ Easy Slide In & Out Multiple Compartments Drawer
- ➔ Designed to fit **EMBERTON™** Kettles

#### Specifications

Dimensions	272mm x 194mm x 85mm
Material	First Grade Bamboo
Weight	1450g



Space Saving Ultra Compact



Removable Drawer for Easy Cleaning

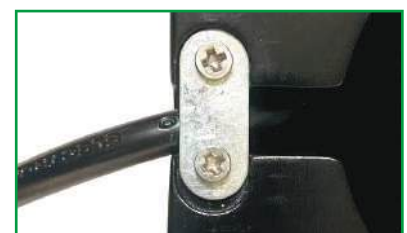

(Kettle, Cups & Ingredients not included)



CERTIFIED  
FOOD  
GRADE



CONDIMENTS  
STORE



1st GRADE  
BAMBOO





## Tongwell Bamboo Welcome Tray

- ➔ Eco Friendly Bamboo
- ➔ Integrated Kettle to Deter Theft
- ➔ Elegant and Compact Design
- ➔ Easy Wipe-Clean Curved Contour Edges
- ➔ First Grade Bamboo Material
- ➔ Space Saving, Modular Design
- ➔ Food Grade Safety
- ➔ Designed to fit **EMBERTON™** Kettles

### Specifications

Dimensions	260mm x 260mm x 30mm
Material	First Grade Bamboo
Weight	850g



Available in Mahogany



CERTIFIED  
FOOD  
GRADE



CONDIMENTS  
STORE



1st GRADE  
BAMBOO



(Kettle, Cups & Ingredients not included)





## WELCOME TRAYS

### Heywood Slate

ABS Welcome Tray with Service Tray & Amenity Holder

**MATT. FINE GRAINED.  
UNIQUE. ELEGANT. REFINED.**

Our HEYWOOD SLATE series offers a unique and creative slate effect - a fine grained MATT finish with the robust material benefits of stain, scratch & heat resistant ABS.

The slender, elegant & stylish design gracefully compliments your guest room - blending perfectly with rooms featuring timber, stone or steel.

- ➔ Innovative & Unique Synthetic Slate Effect Series - ABS
- ➔ Slimline - Elegant & Refined, Stylish & Luxurious
- ➔ Appearance of Natural Slate - perfect blend to compliment rooms featuring timber, stone and steel
- ➔ Durable Stain, Scratch & Heat Resistant ABS
- ➔ Easy Wipe Clean Surface

#### Specifications

	MAIN TRAY	SERVICE TRAY	AMENITY HOLDER
Dimensions	358 x 258 x 10mm	235 x 110 x 10mm	145 x 75 x 40mm
Material	ABS	ABS	ABS
Weight	285g	75g	85g



MAIN TRAY



SERVICE TRAY



AMENITY HOLDER





## Heywood Slate

ABS Welcome Tray with Service Tray & Amenity Holder

(Kettle, Cups & Ingredients not included)





## Heywood Slate

### ABS Compact Tray & Amenity Organiser

MATT. FINE GRAINED.

UNIQUE. ELEGANT. REFINED.

Our HEYWOOD SLATE series offers a unique and creative slate effect - a fine grained MATT finish with the robust material benefits of stain, scratch & heat resistant ABS.

The slender, elegant & stylish design gracefully compliments your guest room - blending perfectly with rooms featuring timber, stone or steel.

- Innovative & Unique Synthetic Slate Effect Series - ABS
- Slimline - Elegant & Refined, Stylish & Luxurious
- Appearance of Natural Slate - perfect blend to compliment rooms featuring timber, stone and steel
- Durable Stain, Scratch & Heat Resistant ABS
- Easy Wipe Clean Surface

#### Specifications

	COMPACT TRAY	AMENITY ORGANISER
Dimensions	330 x 160 x 10mm	125 x 80 x 58mm
Material	ABS	ABS
Weight	170g	120g



COMPACT TRAY



AMENITY ORGANISER



(Kettle, Cups & Ingredients not included)



## Walton ABS Welcome Tray

- ➔ First Grade ABS Material With Wood Grain Effect
- ➔ Integrated Kettle to Deter Theft
- ➔ Removable Perforated Stainless Steel Drip tray to Prevent Spillage
- ➔ All in One Design with Cavities for Sachets, Spoon & Cups
- ➔ Easy Wipe-Clean Curved Contour Edges
- ➔ Space Saving, Modular Design
- ➔ Wood Grain Handfeel to Reduce Finger Marks
- ➔ Tray Accomodates Kettle Base Controller of 143mm Diameter
- ➔ Designed to fit **EMBERTON™** Kettles

### Specifications

Dimensions	<b>460mm x 225mm x 35mm</b>
Material	<b>ABS</b>
Weight	<b>738g</b>



Attractive Design and Easy to Clean



Perforated Stainless Steel Drip Tray



Designed to fit **EMBERTON™** Kettles

(Kettle, Cups & Ingredients not included)



## Andover

### ABS Integrated Welcome Tray

- ➔ First Grade ABS Material With Matt Black Finished
- ➔ Durable Stain, Scratch & Heat Resistant ABS
- ➔ Slimline - Elegant & Refined, Stylish & Luxurious
- ➔ Removable Perforated Matt Black Stainless Steel Drip tray to Prevent Spillage
- ➔ Welcome Tray with space for a Kettle, Sachets, Spoon and Cups
- ➔ Tray Accommodates Kettle Base Controller of 143mm Diameter
- ➔ Anti-theft Function-CORD/CABLE Lock System
- ➔ Designed to fit **EMBERTON™** Kettle



Elegant Soft Contour Design

#### Specifications

Dimension	36.3 x 24.1 x 3cm
Material	ABS
Weight	400g



Anti-theft Cable Lock System



(Kettle, Cups & Ingredients not included)





## Mere

### Kettle Controller Base Adaptor

- ➔ Heat Resistant ABS
- ➔ Exquisitely Crafted Adaptor for Hosting BANBURY Kettle
- ➔ Designed to Fit **EMBERTON™** Trays with 143mm cutout
- ➔ Easy to Install and Remove for Convenient Cleaning
- ➔ The Widened Outer Edge Subtly Resists Contaminants Like Coffee & Sugar Granules
- ➔ Inner Diameter of 131mm

#### Specifications

Dimension	150 x 150mm
Weight	26g



Exquisitely Crafted Adaptor for Hosting BANBURY Kettle

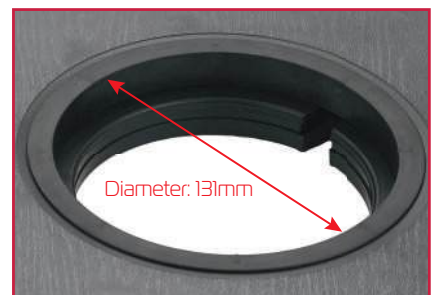

Inner Diameter 131mm



Removable Adaptor for Easy Cleaning





## Halstead Integrated Kettle Welcome Tray (Matt)

- ➔ Integrated Kettle Slot to Deter Theft
- ➔ Robust & Durable Stain, Heat & Scratch Resistant Melamine
- ➔ Space Saving Ultra Compact – uses less space
- ➔ Innovative & Unique Synthetic Slate Effect
- ➔ Elegant Soft Contour Design
- ➔ Neat & Tidy Condiments Presentation
- ➔ Easy Wipe Clean Surface & Contoured Compartments
- ➔ Robust & Sturdy Construction
- ➔ Tray accommodates kettle base controller of 143mm Diameter
- ➔ Designed for use with all **EMBERTON™** kettle types

### Specifications

Dimensions	<b>262mm x 262mm x 30mm</b>
Material	<b>Melamine</b>
Weight	<b>610g</b>



Available in WHITE



Elegant Soft Contour Design

(Kettle, Cups & Ingredients not included)



## Halstead Integrated Kettle Welcome Tray

(Kettle, Cups & Ingredients not included)





## HAIRDRYERS

### Thames

Hotel Safety 1875W Hairdryer with Wall Mount Option  
Matt Black

- ➔ Hotel Safety ON/OFF Press Switch Saves Energy & Safe
- ➔ Dual Safe – Thermostat & Latest Technology Internal Fuse
- ➔ Ceramic Ionic for Smooth Shiny Result
- ➔ Luxurious Soft Touch Finish
- ➔ Powerful 1875 Watt DC Motor
- ➔ 2 Speed/2 Heat & Cool Settings
- ➔ Removable Filter Cover & Safety Mesh Blade Cover
- ➔ Complete with Air-Flow Concentrator for Perfect Styling & Drying
- ➔ Safety Thermostat Over-heating circuit protection
- ➔ Ergonomic Non-Slip Contoured Handle for comfortable use and hold
- ➔ Stylish & Elegant Design
- ➔ Insulated Motor to reduce noise
- ➔ Generous 350 cm Long Extendable COIL cord
- ➔ Built in Hanging Loop
- ➔ Available in EU & BS plug variants

#### Specifications

Power	220-240V, 50/60Hz
Wattage	1800-2200W
Dimensions	240mm x 85mm x 280mm
Certification	CE, CB, ROHS & UKCA Approved
Weight	615g



For BEDROOM use only.  
NOT for use in BATHROOM  
or PUBLIC AREAS



Matt Black Finish



Safety ON/OFF  
Press Switch



Specially Constructed Coil  
to Retain Shape



Wall Holder Option

**Thames**  
Hotel Safety 1875W Hairdryer with Wall Mount Option  
Matt Black



**Harrow**  
1600W Folding Hairdryer  
Matt Black

- ➔ Hotel Safety ON/OFF Press Switch to save energy & safe
- ➔ Dual Safe – Thermostat & Latest Technology Internal Fuse
- ➔ Ceramic Coating with Tourmaline for Smooth Shiny Results
- ➔ Complete with Air-flow Concentrator for Perfect Styling and Drying
- ➔ Cool Shot Switch feature
- ➔ Insulated motor to reduce noise
- ➔ Generous cord length 200cm long
- ➔ Removable Filter for easy cleaning
- ➔ Ergonomic Non-slip contoured handle for comfortable use
- ➔ Built in Hanging Loop
- ➔ Available in EU & BS plug variants



Folds for convenience



2 Speed/Heat settings

Specifications

Power	AC220-240V, 50/60Hz
Wattage	1400-1600W
Dimensions	140mm x 77mm x 231mm
Certification	CE, CB, ROHS & UKCA Approved
Weight	390g







## Emsworth

Hotel Safety Hairdryer 1875W  
Ceramic Ionic

- ➔ Hotel Safety ON/OFF Press Switch Saves Energy & Safe
- ➔ Ceramic Ionic for Smooth Shiny Result
- ➔ Dual Safe – Thermostat & Latest Technology Internal Fuse
- ➔ Powerful 1875Watt DC Motor
- ➔ 2 Speed/3 Heat Settings
- ➔ Removable Filter Cover for Easy Cleaning
- ➔ Magnetic Concentrator - Easy to attach, offers smooth styling experience
- ➔ Safety Thermostat Over-heating Circuit Protection
- ➔ Ergonomic Non-slip Contoured Handle for Comfortable Use and Hold
- ➔ Generous 300 cm Long Extendable COIL Cord
- ➔ Stylish & Elegant Cylindrical Design
- ➔ Matt Black Finish
- ➔ Available in EU & BS Plug Variants

### Specifications

Power	AC220-240V (50-60Hz)
Wattage	1800-2000W
Dimensions	145 x 75 x 260mm
Certification	CE, CB, GS & RoHS Approved
Weight	675g



Wall Mounted Hairdryer Holder Option (Devizes)



2 Speed/ 3 Heat Setting



Specially Constructed Coil to Retain Shape





## Ashford

1600W Hi-Speed Brushless Motor Hairdryer  
Matt Grey

- ➔ Professional Hair Care Dryer
- ➔ High-Speed Brushless Motor 110000RPM
- ➔ Intelligent, Fast-Drying
- ➔ Ionic - Negative Ions
- ➔ Constant Temperature

### Specifications

Power	AC220-240V (50-60Hz)
Wattage	1600W
Dimensions	123 x 270 x 74mm
Certification	CE, CB, UKCA & RoHS Approved
Weight	590g



LED Display Featuring 2 Speed Settings and 3 Heat Levels



Wall Mounted Hairdryer Holder with Anti-theft Cable Track





## Devizes

### Wall Mounted Hairdryer Holder with Anti-Theft Cable Track

- ➔ Built in Anti-theft Cable Tracks
- ➔ Easily Mounts on Wall
- ➔ Suitable for Cylindrical Shape Hairdryer
- ➔ Soft silicone pad with anti-slip function

#### Specifications

Dimensions	90mm x 90mm x 78.5mm
Weight	56g

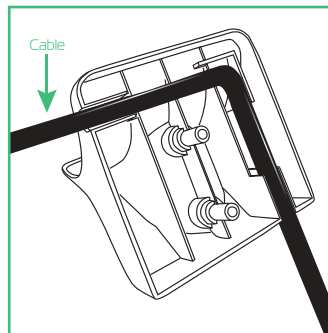

Anti-theft Lock Cable Track



Easily Mounts on Wall



Suitable For Cylindrical Shape Hairdryer







Available in  
WHITE or BLACK

### Mursley

Wall Mounted Hairdryer Holder  
with Anti-Theft Cable Track

- Built in Anti-theft Cable Tracks
- Easily Mounts on Wall
- Soft Glide Lining

Specifications

Dimensions	93mm x 74mm x 50mm
Weight	50g

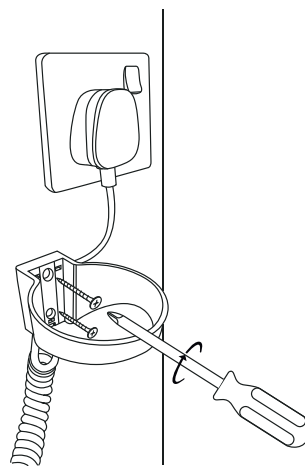

Easily Mounts On Wall



Anti-theft Lock Cable Track



Soft Glide Lining





## Lathbury Hairdryer Bag

- ➔ High Quality Black Soft Velvet
- ➔ Silver Thread Embroidery
- ➔ Strong PP Drawstring
- ➔ Perfect for keeping hairdryers scratch & dust free

### Specifications

Dimensions	400mm x 300mm
Weight	66g



Silver Thread Embroidery



Strong PP Drawstring





## IRONS

### Croft Deluxe

#### 2000W Hotel Safety Steam Iron

- DUAL SAFE Thermostat & Latest Technology Internal Fuse
- ECO Auto Off Function for Extra Energy Saving & Environmental Protection
- Special Anti-drip feature to prevent water dripping through steam outlets after water cools
- FUSION Anti-Leak - New water tank assembly method using a wire frame and latest thermo-weld technology to prevent tank fracture
- 3-way Auto-Cut off Safety Motion Sensor. 30 seconds unattended on soleplate or Side & 5 minutes Upright.
- Super long 300cm cable
- Anti-calc to remove the limescale build up
- Auto Off Indicator Light
- 300 ML Capacity water reservoir
- Red In-Use Indicator Light
- Includes Refill Beaker
- UK or EU Plug variants

#### Specifications

Power	AC220-240V, 50/60Hz
Wattage	2000W
Capacity	300ML
Colour	Black / Grey
Plate Size	22.8 x12.3 cm
Soleplate	Ceramic
Certification	CE, CB, GS, PAHS, UKCA Approved
Weight	1180 g



Powerfull Burst of Steam & Spray  
Vertical & Horizontal



Easy Steam Finger Release Button







Ceramic Soleplate

## Croft Deluxe

2000W Hotel Safety Steam Iron



Available in **WHITE**

## Hertford 1600W Hotel Safety Steam Iron

- ➔ DUAL SAFE Thermostat & Latest Technology Internal Fuse
- ➔ 3 - Way Auto-Cut Off Safety Motion Sensor 30 Seconds unattended on Soleplate or Side and 5 minutes Upright
- ➔ ECO Auto Off Function for extra Energy Saving & Environmental Protection
- ➔ FUSION Anti-Leak - New water tank assembly method using a wire frame and latest thermo-weld technology to prevents tank fracture
- ➔ Special Anti-drip feature to prevent water dripping through steam outlets after water cools
- ➔ Extra long 250cm cable
- ➔ Auto Off Indicator Light
- ➔ Cable cord guard tested to 20,000 cycles to ensure cable safety
- ➔ LED Green & Red In-Use Indicator Light
- ➔ Includes Refil Beaker
- ➔ UK or EU Plug variants



Powerfull Burst of Steam & Spray Vertical & Horizontal



Narrow Front Tip



Self Clean Feature

### Specifications

Power	AC220-240V, 50/60Hz
Wattage	1600W
Capacity	250ML
Colour	Black / Grey
Plate Size	206mm x 113mm
Soleplate	Non-Stick
Certification	CE, CB, RohS & UKCA Approved
Weight	982g





## Yardley

### 1200W Hotel Safety Dry Iron

- Dual Safe – Thermostat & Latest Technology Internal Fuse
- Exclusive Safety 5 minutes Auto Off Motion Sensor
- Uniform Heat Distribution for Smooth Ironing
- Tough Non Stick Soleplate
- 3 - Way Auto-Cut Off Safety Motion Sensor 30 Seconds unattended on Soleplate or Side and 5 minutes Upright
- ECO Auto Off Function for Energy Saving & Environmental Protection
- Operating Light with Cut-Out Indicator
- Generous 250 cm Durable Cord
- Cable cord guard tested to 20,000 cycles to ensure cable safety
- Gloss Skirt with Attractive Black & Grey Design
- UK or EU Plug variants



Large temperature adjustment dial



Overheat safety protection



Narrow Front Tip

#### Specifications

Power	AC220-240V, 50/60Hz
Wattage	1200W
Colour	Black / Grey
Plate Size	200mm x 110mm
Soleplate	Non-Stick
Certification	CE, CB, RohS & UKCA Approved
Weight	745g







## Amphill

### Hotel Safety 2 in 1 Steamer & Iron

#### Why Use EMBERTON™ Garment Steamers

Our AMPHILL Hotel Safety 2 in 1 Steamer & Iron, offers a convenient and effective alternative to traditional ironing. Use for both steam & dry ironing - No iron board required. Professional & wrinkle-free - 2x faster results compared to other steamers.

Time-saving - No hassle to set up ironing boards and waiting for the iron to heat up. Easily steam multiple garments in a short amount of time. Safe & eco-friendly - Garment steamers use only water & heat to generate steam.

- ➔ Powerful - 1950W
- ➔ Safety Auto Shut Off - 5 minutes
- ➔ Continuous Steam Action
- ➔ Steam Rate 20-30 grams/minute
- ➔ Long 250cm power cord for convenience
- ➔ Steam & Dry Ironing - Vertically & Horizontally

#### Specifications

Power	AC220-240V (50-60Hz)
Wattage	1650-1950W
Water Tank Capacity	170ML
Colour	Black / Grey
Soleplate	Double Layer Ceramic
Soleplate Size	133 x 88mm
Unit Size	413 x 92 x 143mm
Certification	CE, GS, CB, UKCA & RoHS Approved



Iron Horizontally



Steam Vertically



30 Seconds Heat-Up Time





## Cheshunt

### Hotel Safety 2 in 1 Digital Steamer & Iron

#### Why Use EMBERTON™ Garment Steamers

Our CHESHUNT Hotel Safety 2 in 1 Steamer & Iron, offers a convenient and effective alternative to traditional ironing. Use for both steam & dry ironing - No iron board required. Professional & wrinkle-free - 2x faster results compared to other steamers.

Time-saving - No hassle to set up ironing boards and waiting for the iron to heat up. Easily steam multiple garments in a short amount of time. Safe & eco-friendly - Garment steamers use only water & heat to generate steam.

- ➔ Powerful - 1800W
- ➔ Safety Auto Shut Off - 5 minutes
- ➔ Continuous Steam Action
- ➔ Steam Rate 18-25 grams/minute
- ➔ Long 250cm power cord for convenience
- ➔ Steam & Dry Ironing - Vertically & Horizontally

#### Specifications

Power	AC220-240V (50-60Hz)
Wattage	1400-1800W
Water Tank Capacity	180ML
Colour	Black / Grey
Soleplate	Double Layer Ceramic
Soleplate Size	143 x 97mm
Unit Size	362 x 97 x 180mm
Certification	CE, GS, CB, UKCA & RoHS Approved



One Button with LED Display



Iron Horizontally



Steam Vertically





## Steamer Bag

Steamer & Iron 2 in 1 Bag

- Heat Resistant Cotton
- Silver Thread Embroidery
- Strong PP Drawstring
- Design to Fit **EMBERTON™** Steamer & Iron

### Specifications

Dimensions	460mm x 252mm
Weight	35g



Silver Thread Embroidery



Strong PP Drawstring







## IRONING BOARDS



### Ironing Board Engineered Series

Our super strong series of tough ironing board is a result of extensive research and development with industry professionals and hotels., working closely to identify the needs, habits and often rough treatment of hotel ironing boards.

Rugged & Durable - We have combined a rugged frame with heavy duty metal components and robotic welds to withstand guests' tough use.

#### THE ULTIMATE STRENGTH IN IRONING BOARDS

- ➔ Tube Frame Legs 38mm/28mm
- ➔ Strong Double Handle Height Adjustment Lever
- ➔ Steam Flow Metal Mesh Top
- ➔ 2mm Foam and 5mm Felt Combination Padding
- ➔ Smooth Binding Edges to Withstand Fraying
- ➔ Cover Material : Cotton with Felt Underlay
- ➔ Cover Colour : Charcoal Grey
- ➔ Frame Colour : Silver Grey

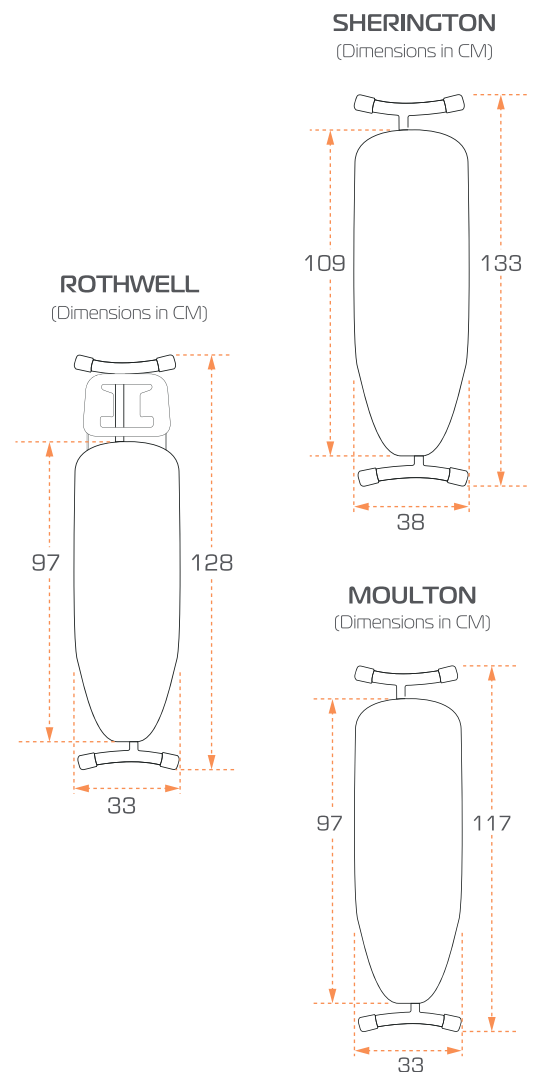

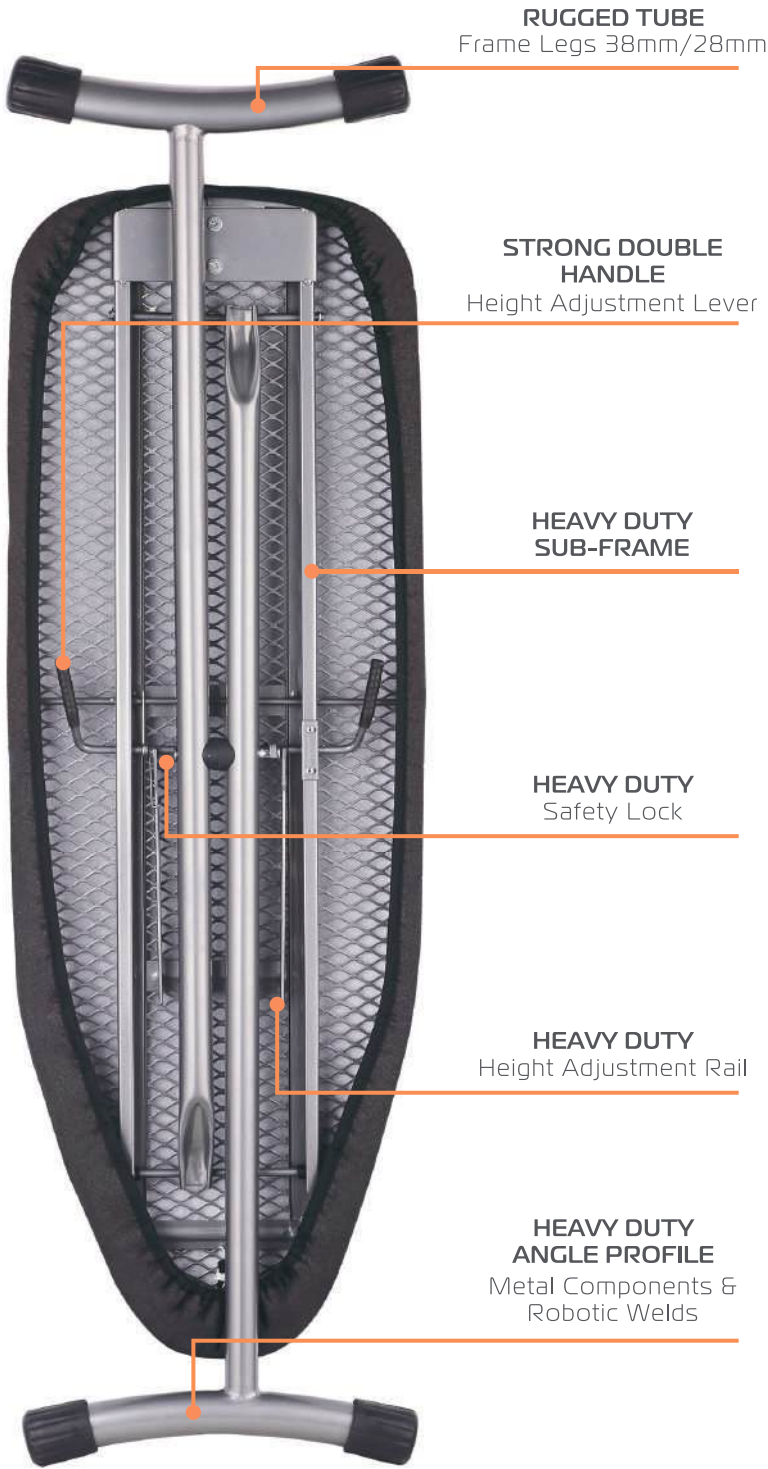

**SHERINGTON**  
109(L) x 38(D) x 87(H)cm



**ROTHWELL**  
116(L) x 33(D) x 76(H)cm



**MOULTON**  
97(L) x 33(D) x 76(H)cm



Metallic Heat Reflective Iron Board Cover



Smooth Bound Edges to Avoid Fraying



2mm foam & 5mm felt Combination Padding



Steam Flow Metal Mesh Top



New Generation  
**Ironing Centres Safety & Storage**



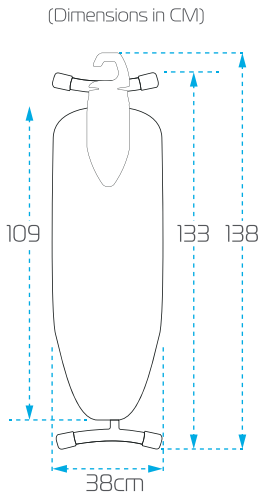

**SHERINGTON**  
Full Size Ironing Board

**BROMHAM**  
Ironing Centre



DEENE + YARDLEY  
1200W Dry Iron

OR

**KINGSMEAD**  
Ironing Centre



CHORLEY + HERTFORD  
1600W Steam Iron

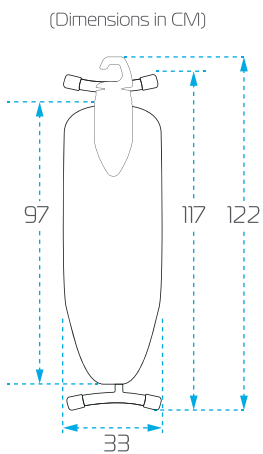

**MOULTON**  
Compact Size Ironing Board

**ELSTOW**  
Ironing Centre



DEENE + YARDLEY  
1200W Dry Iron

OR

**STAGSDEN**  
Ironing Centre



CHORLEY + HERTFORD  
1600W Steam Iron





Wall mounted



Rapid cable tidy slot. Cables can be bundled and inserted to save time



Integrated cable wrap Stores neatly



Optional holder To mount ironing board

## Stroud Ironing Centre

**SAFE. ROBUST. CONVENIENT.**  
PATENTED DESIGN

- ➔ Unique and Patented Design – sliding frame design secures iron
- ➔ Convenient, Easy and Safe – swivel, lift out & replace during ironing
- ➔ Universal Fitting - Suits and fits almost all iron types and sizes
- ➔ Protective Silicon Pad protects soleplate



84mm Adjustments



Protective silicon pad to prevent soleplate damage and absorb heat

Design Protected by International Registered Designs & Patents Pending © Emberton Group Inc





Heat resistant pad to prevent soleplate damage and absorbs heat



Integrated cable wrap. Cables can be neatly wrapped around frame



Holder Angle matches iron shape for Perfect Fit



Rapid cable tidy slot. Cables can be gathered and inserted directly in slot to save time



Optional J Hook to hang ironing board

## Somerton

### Universal Iron & Iron Board Storage

#### SECURES IRON TO PREVENT FALLING HAZARD UNIQUE & PATENTED

- ➔ Convenient, Easy & Safe - Easy lift in and lift out with frame design to prevent falling hazard
- ➔ Universal Fitting - Fits almost all iron types and sizes
- ➔ Soft Coated Protective Quality Steel Frame - protects iron from scratches and damage

#### Dimensions

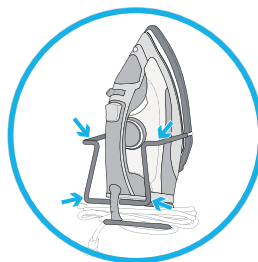

**Z Shape Frame**  
Prevents Iron Falling Hazard



Design Protected by  
International Registered Designs  
& Patents Pending  
© Emberton Group Inc







**HEAT RESISTANT PROTECTIVE IRON PAD**  
to prevent sole plate damage and absorb heat



360° Swivel



**INTEGRATED CORD WRAP**  
Cord may be neatly wrapped using Silicone Cord Wrap



Spring Pressure Slide Wings



**OPTIONAL J HOOK TO HANG IRONING BOARD**

## Oakham Safety Grip Iron Store

Oakham's Safety Frame Design prevents falling hazards. With patented, spring loaded Slide Guides for safe and firm grip to keep iron in position safely. Convenient and easy to insert and lift out. Durable construction and universal design to fit most iron types.

- ➔ Unique Guide & Slide Safety Solution
- ➔ Holds Iron Securely
- ➔ Strong & Sturdy
- ➔ Improves Guest Room Safety

### Specifications

Plate Dimension	247 x 159 x 24mm
Plate Weight	197g
Cable Wrap Dimension	300 x 16mm
Cable Wrap Thickness	3.75mm



Design Protected by International Registered Designs & Patents Pending © Emberton Limited





**PROTECTIVE SILICONE PAD**  
to prevent sole plate damage and absorb heat



**HOLDER ANGLE**  
matches steamer shape for perfect fit



**INTEGRATED CABLE WRAP**  
Cables can be neatly wrapped around the frame



**SOLID & STURDY HOOK**  
easily to hang clothes for ironing

**Crawley**  
Universal Steamer Holder with Anti-Theft Function

- Convenient, Easy & Safe – Easy to lift on and lift out with frame design to prevent falling hazard
- Designed to fit Emberton™ Steamer
- Protective Silicone Pad protects soleplate and prevent scratches
- Anti-Theft Cable Lock included
- Durable and Robust Hook- Makes hanging clothes for ironing easy



Two Hooks for Hanging Clothes

Specifications

Holder Dimension	290 x 120 x 123 mm
Holder Weight	350g

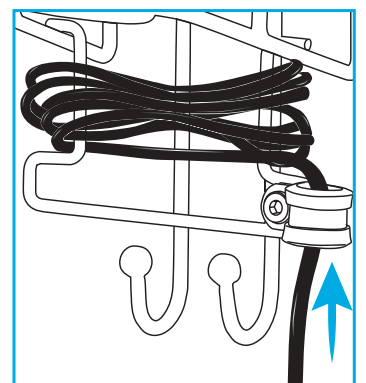

Anti-theft Cable Lock



Secure & safe to prevent falling



Open Rail Sandhurst available



## Sandhurst

### Universal Iron Board Holder & Store

- ➔ Unique and Patented Design Instant & Easy to Fit
- ➔ Ultimate safety – specially designed U frame safely secures iron board to prevent falling out
- ➔ Universal – Suits all sizes of T Leg Ironing Boards
- ➔ Easy to remove and replace ironing board
- ➔ Fits regular door or wall hooks
- ➔ Stores iron board neatly on rail
- ➔ Robust & Rigid - Strong welded joints with welded plate centre
- ➔ Thick 5mm steel and strong welded plate for years of trouble free use
- ➔ Durable NON slip finish to hold iron board securely in place
- ➔ Durable rubberized protective coating finish prolongs life of iron board frame and coating

#### Specifications

Dimensions	<b>65(W) x 126(H) x 62(D) mm</b>
Material	<b>5mm Steel with Welded Joints</b>
Weight	<b>27g</b>



Neat & tidy wardrobe storage



Stores Boards on Wall Hooks

Design Protected by International Registered Designs & Patents Pending © Emberton Group Inc







**RECESS BOLT HOLES**  
for Flush Fitting Bolts



**SPECIAL PROFILE**  
Keeps Board Clear of Wall

## Hyde

### Ironing Board Wall Holder

- ➔ Made of Heavy Duty Carbon Steel
- ➔ Durable Silver Powder Coated Finish
- ➔ Compact and Strong
- ➔ Recess Bolt Holes for Flush Fitting Bolts
- ➔ Mounts To The Wall To Store Ironing Board
- ➔ Stores Ironing Board neatly

#### Specifications

Dimensions	<b>170(W) x 74(H) x 40 (D) mm</b>
Material	<b>Quality Carbon Steel</b>
Weight	<b>160g</b>

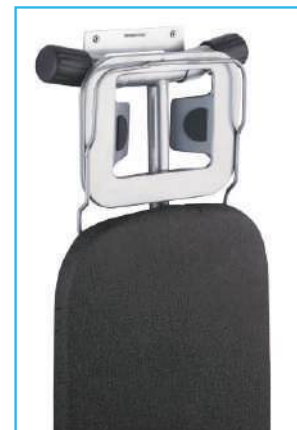

Space Saving



Curved angle is a perfect match  
for Tough Board frame





## Chesham

### 35L Minibar Fridge Silent Thermoelectric (Solid Door)

- ➔ Average Energy Consumption Per Year at an Ambient Temperature of 25°C and a Cooling Temperature of 8°C According to EN 1060/2010
- ➔ ErP Level: Class E
- ➔ Noise: 22dB (Class A)
- ➔ Non-wearing Peltier Thermoelectric
- ➔ Fuzzy Logic Control System For Low Energy Consumption
- ➔ No Moving Parts - 100% Silent and Vibration Free
- ➔ Environmentally Friendly - Ammonia Free
- ➔ Height-adjustable & Removable Shelves
- ➔ Soft LED Interior Light With Door Sensor
- ➔ Automatic Drain Water Evaporation
- ➔ OPTIONAL Extra - With Key & Lock and Power On/Off Switch

#### Specifications

Product Dimension	385(W) x 455(D) x 485(H)mm
Capacity	35L
Colour	Black / Solid Door
Voltage	100-240V
Power	58W
Heater Power	10W
Refrigeration	R600a
Insulation	Cyclopentane
Certification	UKCA, CE, CB & RoHS Approved
Weight	11.6kg



Power Switch - Energy Saving in Unoccupied Rooms (OPTIONAL)



With Key & Lock (OPTIONAL)





**Brixham**  
35L Minibar Fridge Silent  
Thermoelectric (Glass Door)

- ➔ Average Energy Consumption Per Year at an Ambient Temperature of 25°C and a Cooling Temperature of 8°C According to EN 1060/2010
- ➔ ErP Level: Class D
- ➔ Noise: 22dB (Class A)
- ➔ Non-wearing Peltier Thermoelectric
- ➔ Fuzzy Logic Control System For Low Energy Consumption
- ➔ No Moving Parts - 100% Silent and Vibration Free
- ➔ Environmentally Friendly - Ammonia Free
- ➔ Height-adjustable & Removable Shelves
- ➔ Soft LED Interior Light With Door Sensor
- ➔ Automatic Drain Water Evaporation
- ➔ OPTIONAL Extra - With Key & Lock and Power On/Off Switch

Specifications

Product Dimension	385(W) x 455(D) x 485(H)mm
Capacity	35L
Colour	Black / Glass Door
Voltage	100-240V
Power	58W
Heater Power	10W
Refrigeration	R600a
Insulation	Cyclopentane
Certification	UKCA, CE, CB & RoHS Approved
Weight	13.7kg



Chilled Refreshments



Power Switch - Energy Saving in Unoccupied Rooms (OPTIONAL)



With Key & Lock (OPTIONAL)





## Penzance

### 40L Minibar Fridge Silent Thermoelectric (Solid Door)

- ➔ Average Energy Consumption Per Year at an Ambient Temperature of 25°C and a Cooling Temperature of 8°C According to EN 1060/2010
- ➔ ErP Level: Class E
- ➔ Noise: 22dB (Class A)
- ➔ Non-wearing Peltier Thermoelectric
- ➔ Fuzzy Logic Control System For Low Energy Consumption
- ➔ No Moving Parts - 100% Silent and Vibration Free
- ➔ Environmentally Friendly - Ammonia Free
- ➔ Height-adjustable & Removable Shelves
- ➔ Soft LED Interior Light With Door Sensor
- ➔ Automatic Drain Water Evaporation
- ➔ OPTIONAL Extra - With Key & Lock and Power On/Off Switch

#### Specifications

Product Dimension	400(W) x 425(D) x 560(H)mm
Capacity	40L
Colour	Black / Solid Door
Voltage	100-240V
Power	58W
Heater Power	10W
Refrigeration	R600a
Insulation	Cyclopentane
Certification	UKCA, CE, CB & RoHS Approved
Weight	12.5kg



Chilled Refreshments



Power Switch - Energy Saving in Unoccupied Rooms (OPTIONAL)



With Key & Lock (OPTIONAL)







**Redditch**  
40L Minibar Fridge Silent  
Thermoelectric (Glass Door)

- ➔ Average Energy Consumption Per Year at an Ambient Temperature of 25°C and a Cooling Temperature of 8°C According to EN 1060/2010
- ➔ ErP Level: Class D
- ➔ Noise: 22dB (Class A)
- ➔ Non-wearing Peltier Thermoelectric
- ➔ Fuzzy Logic Control System For Low Energy Consumption
- ➔ No Moving Parts - 100% Silent and Vibration Free
- ➔ Environmentally Friendly - Ammonia Free
- ➔ Height-adjustable & Removable Shelves
- ➔ Soft LED Interior Light With Door Sensor
- ➔ Automatic Drain Water Evaporation
- ➔ OPTIONAL Extra - With Key & Lock and Power On/Off Switch

Specifications

Product Dimension	400(W) x 410(D) x 570(H)mm
Capacity	40L
Colour	Black / Glass Door
Voltage	100-240V
Power	58W
Heater Power	10W
Refrigeration	R600a
Insulation	Cyclopentane
Certification	UKCA, CE, CB & RoHS Approved
Weight	15.2kg



Chilled Refreshments



Power Switch - Energy Saving in Unoccupied Rooms (OPTIONAL)



With Key & Lock (OPTIONAL)





**Kendal**  
40L Minibar Fridge  
Absorption (Solid Door)

- ➔ Cooling System: Absorption
- ➔ EER Level: Class G
- ➔ Noise: 23dB (Class A)
- ➔ ECO Temperature: 4°C to 9°C
- ➔ Ambient Temperature: 25°C
- ➔ Multiple Adjustable Shelf Levels
- ➔ Internal LED Light
- ➔ OPTIONAL Extra - With Key & Lock and Power On/Off Switch

Specifications

Product Dimension	400(W) x 425(D) x 560(H)mm
Capacity	40L
Colour	Black / Solid Door
Voltage	220-240V / 110V
Power	60W
Refrigeration	R717
Insulation	Cyclopentane
Certification	UKCA, CE, CB, & RoHS Approved
Weight	12.5kg



Chilled Refreshments



Power Switch - Energy Saving in Unoccupied Rooms (OPTIONAL)



With Key & Lock (OPTIONAL)



**Romney**  
40L Minibar Fridge  
Absorption (Glass Door)

- ➔ Cooling System: Absorption
- ➔ EER Level: Class G
- ➔ Noise: 26dB (Class A)
- ➔ ECO Temperature: 10°C to 15°C
- ➔ Ambient Temperature: 25°C
- ➔ Multiple Adjustable Shelf Levels
- ➔ Internal LED Light
- ➔ OPTIONAL Extra - With Key & Lock and Power On/Off Switch

Specifications

Product Dimension	400(W) x 420(D) x 570(H)mm
Capacity	40L
Colour	Black / Glass Door
Voltage	220-240V / 110V
Power	60W
Refrigeration	R717
Insulation	Cyclopentane
Certification	UKCA, CE, CB, & RoHS Approved
Weight	15.2kg



Chilled Refreshments



Power Switch - Energy Saving in Unoccupied Rooms (OPTIONAL)



With Key & Lock (OPTIONAL)



## Derby 14" Open Top Safe

- ➔ Programmable Digital Lock with User and Master Codes
- ➔ Override Key Included for Emergency Use
- ➔ One-way Live Locking Door Bolts
- ➔ Anchor Bolts Included to Mount Safe to Wall or Floor
- ➔ Run on 4 AA Batteries (Excluded)
- ➔ Optional Audit Trail Reader That Can Display or Print The Last 100 Openings
- ➔ Carpet Mat Padding on Inside Bottom

### Specifications

Product Dimension	400(W) x 350(D) x 130(H)mm
Door Thickness	3mm
Body Thickness	1.5mm
Colour	Black / Grey
Battery	Operates on 4 AA Batteries (Not Included)
Certification	CE Approved
Weight	8.5kg



Ideal for Storage of Valuable Items



Fit in Drawer



CEU Slot - Optional  
Audit Trail Reader





## Dewsbury

15" & 17" Hotel Safe

### Hotel Safe

- ➔ Bright LED Keypad Display
- ➔ Programmable Digital Lock with 4 to 6 Digit User Input
- ➔ Override Key Included for Emergency Use
- ➔ Bright Interior LED Lighting
- ➔ Motorised Locking Door Bolts
- ➔ Carpet Lined Interior Base
- ➔ Anchor Bolts Included to Mount Safe to Wall or Floor
- ➔ Optional Audit Trail Reader to Display or Print Opening Records

### Specifications

Product Dimension	420(W) x 360(D) x 190(H)mm (15")
Product Dimension	420(W) x 480(D) x 190(H)mm (17")
Door Thickness	4mm
Body Thickness	1.5mm
Colour	Black
Battery	Operates on 4 AA Batteries (Not Included)
Certification	CE Approved
Weight	8.5kg (15")
Weight	10kg (17")



Programmable Digital Lock with 4 to 6 Digit User Input



Bright Interior LED Lighting



CEU Slot - Optional Audit Trail Reader



## Witney 15" & 17" Hotel Safe

### Hotel Safe

- ➔ Bright LED Keypad Display
- ➔ Programmable Digital Lock with 4 to 6 Digit User Input
- ➔ Override Key Included for Emergency Use
- ➔ Bright Interior LED Lighting
- ➔ Motorised Locking Door Bolts
- ➔ Carpet Lined Interior Base
- ➔ Anchor Bolts Included to Mount Safe to Wall or Floor
- ➔ Optional Audit Trail Reader to Display or Print Opening Records

### Specifications

Product Dimension	420(W) x 360(D) x 190(H)mm (15")
Product Dimension	420(W) x 480(D) x 190(H)mm (17")
Door Thickness	4mm
Body Thickness	1.5mm
Colour	Black
Battery	Operates on 4 AA Batteries (Not Included)
Certification	CE Approved
Weight	8.5kg (15")
Weight	10kg (17")



15" & 17" Model is Easy to Store Widescreen Laptops



Bright Interior LED Lighting



CEU Slot - Optional Audit Trail Reader



## ACCESSORIES & ROOM ESSENTIALS

### Bodmin

Multi-Function Alarm Clock with Wireless Charging & Speaker

- ➔ Built-in Latest Wireless Connection Technology & Able to Pair with Almost All Compatible Devices
- ➔ Highest Quality Speaker - 5 Wattage Full Frequency Loudspeaker each for Dynamic Audio
- ➔ Hassle-free Wireless Charger with Fast Charging Technology feature & Compatibles with Almost All Support Devices
- ➔ Available setting of Wireless pairing, Dual Alarm Clock setting, Snooze Alarm Mode, AUX Audio & FM Radio, TF Card and Double USB Port for wire-style pairing
- ➔ Ultra Large LCD Display with Anti-Scratch Screen, adjustable LCD Screen Brightness and Day, Time details display
- ➔ Back-up Clock Memory with 2x 1.5V AAA Batteries
- ➔ Optional USB Type-C Adaptor & Screw fixing point with Anti-Theft Cable
- ➔ Battery Slot with Secured Cover

#### Specifications

Power	AC 110 – 240V, 50-60Hz
Wireless Charger Wattage	10W
Battery (Optional)	2 x 1.5V AAA Batteries (NOT INCLUDED)
Dimensions	128mm (L) x 102mm (W) x 77mm (H)
Certification	CE, UKCA, FCC, ROHS & CCC Approved
Weight	0.45 Kg



Available Setting Options



Optional USB Type-C Adaptor



Optional Screw Type Anti-Theft Cable





Fast Charging Technology

## **Bodmin** Multi-Function Alarm Clock with Wireless Charging & Speaker





## Alton USB Rechargeable Torchlight

- ➔ Light & Compact Portable Design – Mini and handy size to keep in the pocket
- ➔ Charging a cell phone as an emergency power bank
- ➔ Zoom in or out the torchlight to adjust the brightness intensity of illumination area
- ➔ IPX4-rated water-resistant and designed for use in a rainy day
- ➔ Build in rechargeable battery with micro USB charging in 2 hours and constant brightness up to 4 hours!
- ➔ Bottom of the torchlight is equipped with a lanyard for easy hanging and carrying
- ➔ Bright & Powerful - 4 Modes: High, Low, Flash and Zoomable light
- ➔ Suitable for Hotel Housekeeping or Outdoor activities

### Specifications

Torchlight Dimension	<b>137 x 36 x 27 MM</b>
Product Weight	<b>0.098KG</b>
Power	<b>10W</b>
Battery	<b>Built-in 1200mAh</b>
Charging Port	<b>Micro USB port</b>
Charging Time	<b>2 hrs</b>
Input Voltage	<b>5V</b>
Waterproof Rate	<b>IPX4</b>
Working Hours	<b>2.5-4 hrs</b>



Light & Portable Design



Built-in 1200mAh rechargeable battery



Come with USB cable & pouch for easy carry





## ACCESSORIES & ROOM ESSENTIALS

### Woburn

#### **PUSHPOWER** Digital Bathroom Scale

- ➔ BATTERY-FREE – powered by **PUSH POWER** Button
- ➔ 4 High Precision Sensors for Accurate Weight
- ➔ TOUGHENED SAFETY GLASS 8MM Thickness
- ➔ ULTRA LARGE LCD Display
- ➔ Modern, Elegant & Stylish Design
- ➔ Stable & Rigid Platform
- ➔ Overload & Error Indication
- ➔ Weight up to 180 kgs
- ➔ Auto Switch OFF
- ➔ Units in KGS & LBS

#### Specifications

Dimensions	310mm x 310mm x 30mm
Material	8mm Toughened Safety Glass
Certification	CE, UKCA & RoHS
Weight	1.6 kg



Battery-Free  
**PUSH POWER** Button



Ultra Large LCD Display



8mm Ultra-Tough Glass



**Woburn**  
**PUSHPOWER** Digital Bathroom Scale



## Whitehill Stainless Steel Scale

- ➔ High Precision Sensors for accurate weight
- ➔ Smudge-resistant and easy-to-clean high quality Stainless Steel 304 Platform
- ➔ Anti-Fingerprint coating to reduce scratches
- ➔ Weight up to 180kgs
- ➔ Stable & Rigid Platform
- ➔ Overload & Error Indication
- ➔ Low Battery Indicator
- ➔ Units in KGS, LBS & STONES

### Specifications

Dimensions	300 x 300 x 220mm
Battery	2xAAA battery included
Material	Stainless Steel + 6mm Tempered Glass
Certification	CE, UKCA & RoHS Approved
Weight	1.69kg



304 Stainless Steel & 6mm Tempered Glass



Wide LCD Display  
76mm x 40mm



Stable and Rigid Platform  
with Anti-fingerprint coating







## Wilton Bamboo Black Scale

- ➔ High Precision Sensors for accurate weight
  - ➔ High-quality, anti-mildew surface made out of real bamboo 15mm thickness
  - ➔ Weight up to 180kgs
  - ➔ Stable & Rigid Platform
  - ➔ Overload & Error Indication
  - ➔ Low Battery Indicator
  - ➔ Units in KGS, LBS & STONES
  - ➔ Designed & Manufactured for use in Guest Bedrooms, Living Rooms, Suites etc.
- \*NOT SUITABLE FOR USE IN BATHROOMS**

### Specifications

Dimensions	300 x 300 x 31 mm
Voltage	3V
Battery	3 x AAA Batteries Included
Material	15mm Real Bamboo
Certification	CE, UKCA & RoHS Approved
Weight	1.105kg



15 mm Real Bamboo



Wide LCD Display  
76mm x 40mm



Stable & Rigid  
Platform





## Wilton Bamboo Natural Scale

- ➔ High Precision Sensors for accurate weight
  - ➔ High-quality, anti-mildew surface made out of real bamboo 15mm thickness
  - ➔ Weight up to 180kgs
  - ➔ Stable & Rigid Platform
  - ➔ Overload & Error Indication
  - ➔ Low Battery Indicator
  - ➔ Units in KGS, LBS & STONES
  - ➔ Designed & Manufactured for use in Guest Bedrooms, Living Rooms, Suites etc.
- \*NOT SUITABLE FOR USE IN BATHROOMS**

### Specifications

Dimensions	300 x 300 x 31 mm
Voltage	3V
Battery	3 x AAA Batteries Included
Material	15mm Real Bamboo
Certification	CE, UKCA & RoHS Approved
Weight	1.105kg



15 mm Real Bamboo



Wide LCD Display  
76mm x 40mm



Stable & Rigid  
Platform





## Fairford Digital Bathroom Scale

- ➔ Unique & Patented Soft Grip Touch
- ➔ Improved Anti-Slip Performance
- ➔ 4 High Precision Sensors for Accurate Weight
- ➔ Non slip glass with 8mm tempered glass
- ➔ Auto Switch ON/OFF Saves Battery Life
- ➔ Modern, Elegant & Stylish Design
- ➔ Weight range 5 to 180 kgs
- ➔ Overload & Error Indication
- ➔ Stable & Rigid Platform
- ➔ Units in KGS, LBS or STONES
- ➔ Low Battery Indicator

### Specifications

Dimensions	<b>300 x 300 x 22mm</b>
Voltage	<b>3V</b>
Battery	<b>2 x CR2032 Lithium Ion Batteries included</b>
Material	<b>8mm Toughened Safety Glass</b>
Certification	<b>CE, UKCA &amp; RoHS Approved</b>
Weight	<b>1.985kg</b>



Wide LCD Display  
81mm x 43mm



Improved Anti-slip  
Performance



Stable and Rigid Platform  
with Anti-fingerprint coating



## Ashton Digital Bathroom Scale

- ➔ High Precision Sensors for accurate weight
- ➔ Auto ON & OFF
- ➔ Modern, Elegant & Stylish Design
- ➔ Weighs up to 180 kgs
- ➔ Stable & Rigid Platform
- ➔ Units in KGS & LBS



Toughened Safety Glass  
8mm thickness



Wide LCD Display  
75mm x 31mm

### Specifications

Dimensions	<b>300 x 300 x 24mm</b>
Voltage	<b>3V</b>
Battery	<b>2 x AAA Batteries included</b>
Material	<b>8mm Toughened Safety Glass</b>
Certification	<b>CE, UKCA &amp; RoHS</b>
Weight	<b>1.95kg</b>







## 1600W Cylindrical Hairdryer

- ➔ Powerful 1600W DC Motor
- ➔ 2 Speed/Heat & Cool Setting
- ➔ Removable Filter for Easy Cleaning
- ➔ Complete with Air-Flow Concentrator for Perfect Styling & Drying
- ➔ Soft Touch Matt Finish
- ➔ Generous cord length 180cm Long
- ➔ Safety Thermostat Over-heating circuit protection
- ➔ Available in EU & UK Plug Variants

### Specifications

Power	1400-1800W
Voltage	220-240V, 50-60Hz
Hairdryer Dimension	177 x 235 x 75mm
Certification	CE, CB, UKCA, GS
Product Weight	530g



Removable Filter



Removable Concentrator



2 Speed/Heat & Cool settings





## Emergency Torchlight Instant - ON

- ➔ High Energy-Efficiency & Quality – 13 LED light with 50,000 hours lifespan
- ➔ INSTANT-ON feature - The torch will illuminate immediately when removed from holder if left in ON mode and replaced in holder.
- ➔ Aluminum Oxidation Finishing Flashlight with ABS Holder
- ➔ Estimated 12 - 24 hours long per usage period
- ➔ Non-slip contoured handle for comfortable use
- ➔ Easy installation – Included complete set of screws and screw anchors

NOTE: Please use rechargeable lithium battery ONLY (Not Included) for rechargeable function

### Specifications

Power	<b>AC 100V-250V, 50 – 60Hz</b>
Battery	<b>x3 1.5V AA Alkaline or Lithium Batteries (NOT INCLUDED)</b>
Wattage	<b>3.9 Watts-hours</b>
Lumen	<b>120 lumen</b>
Beam Angle	<b>180°</b>
Light Colour	<b>White Light</b>
Material	<b>Aluminum and ABS</b>
Holder Dimension	<b>175mm x 60mm</b>
Torchlight Dimension	<b>178mm x 44 mm</b>
Certification	<b>CE approved</b>
Weight	<b>0.28 kg</b>



On/Off  
Press  
Switch

All Black Aluminum  
Oxidation Finishing



Charger Slot

Anti-theft Wall  
Mounted Holder





# SPECIFICATIONS

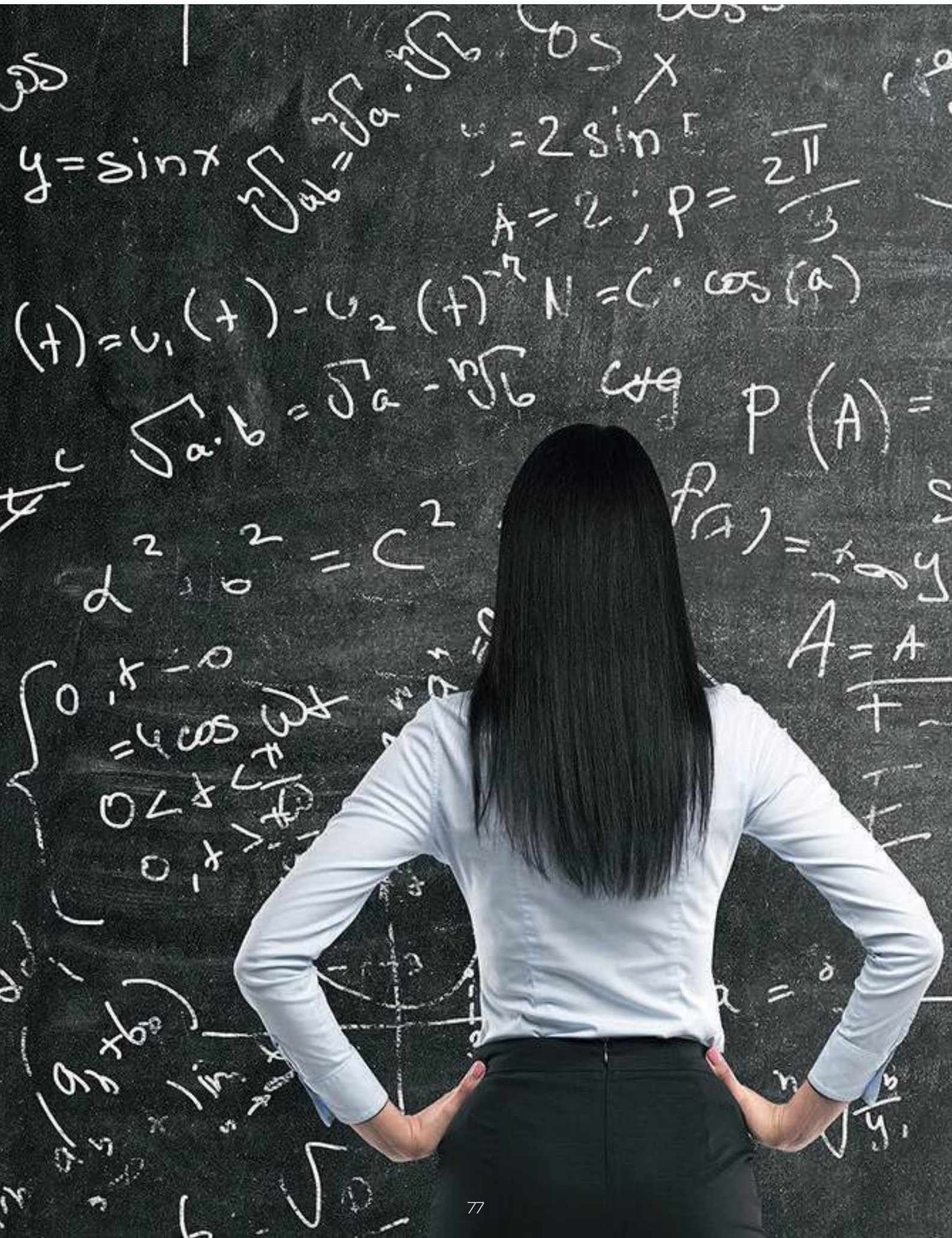

# SPECIFICATIONS - KETTLES



Model	Evesham - Steel / Black	Evesham - Steel / Black	Evesham - Black
Art No	EH50714 (EU Plug-EH Controller) EH50716 (EU Plug-Strix Controller)	EH50715 (UK Plug-EH Controller) EH50717 (UK Plug-Strix Controller)	EH50724 (EU Plug-EH Controller) EH50722 (EU Plug-Strix Controller)
Page	5	5	5
Power	220-240V, 50-60Hz	220-240V, 50-60Hz	220-240V, 50-60Hz
Wattage	1500-1800W	1500-1800W	1500-1800W
Capacity	1 Litre	1 Litre	1 Litre
DUAL SAFE	Yes	Yes	Yes
Material	Polypropylene High Grade SS304 Stainless Steel Body & Heat Plate Double Layer Safety Insulation	Polypropylene High Grade SS304 Stainless Steel Body & Heat Plate Double Layer Safety Insulation	Polypropylene High Grade SS304 Stainless Steel Body & Heat Plate Double Layer Safety Insulation
Overall Height	220mm	220mm	220mm
Top Diameter	88mm	88mm	88mm
Base Diameter	143mm	143mm	143mm
Weight	930g	930g	930g
Certification			
Mark/Warranty	8pcs - 69.5 x 20.7 x 44cm 9.6kg 0.0633CBM	8pcs - 69.5 x 20.7 x 44cm 9.6kg 0.0633CBM	8pcs - 69.5 x 20.7 x 44cm 9.6kg 0.0633CBM
Packaging Details			
Barcodes	EH50714 (EU Plug-EH Controller)  EH50716 (EU Plug-Strix Controller) 	EH50715 (UK Plug-EH Controller)  EH50717 (UK Plug-Strix Controller) 	EH50724 (EU Plug-EH Controller)  EH50722 (EU Plug-Strix Controller) 



Model	Evesham - Black	Malvern Brushed Stainless Steel	Malvern Black
Art No	EH50725 (UK Plug-EH Controller) EH50723 (UK Plug-Strix Controller)	EH50550 (EU Plug-EH Controller) EH50635 (EU Plug-Strix Controller) EH50634 (UK Plug-Strix Controller)	EH50726 (EU Plug-EH Controller) EH50643 (EU Plug-Strix Controller) EH50644 (UK Plug-Strix Controller)
Page	5	7	7
Power	220-240V, 50-60Hz	220-240V, 50-60Hz	220-240V, 50-60Hz
Wattage	1500-1800W	800-950W	800-950W
Capacity	1 Litre	0.5 Litre	0.5 Litre
DUAL SAFE	Yes	Yes	Yes
Material	Polypropylene High Grade SS304 Stainless Steel Body & Heat Plate Double Layer Safety Insulation	High Grade SS304 Stainless Steel Body & Heat Plate	High Grade SS304 Stainless Steel Body & Heat Plate
Overall Height	220mm	185mm	185mm
Top Diameter	88mm	90mm	90mm
Base Diameter	143mm	143mm	143mm
Weight	930g	770g	770g
Certification			
Mark/Warranty	8pcs - 69.5 x 20.7 x 44cm 9.6kg 0.0633CBM	12pcs - 52.5 x 39.5 x 38cm 11.82kg 0.079CBM	12pcs - 52.5 x 39.5 x 38cm 11.82kg 0.079CBM
Packaging Details			
Barcodes	EH50725 (UK Plug-EH Controller)  EH50723 (UK Plug-Strix Controller) 	EH50550 (EU Plug-EH Controller)  EH50634 (UK Plug-Strix Controller)  EH50635 (EU Plug-Strix Controller) 	EH50726 (EU Plug-EH Controller)  EH50644 (UK Plug-Strix Controller)  EH50643 (EU Plug-Strix Controller) 



# SPECIFICATIONS - KETTLES



Model	Corsham Brushed Stainless Steel	Corsham Black	Corsham Black
Art No	EH50633 (EU Plug-EH Controller) EH50637 (EU Plug-Strix Controller) EH50636 (UK Plug-Strix Controller)	EH50705 (EU Plug-EH Controller) EH50729 (EU Plug-Strix Controller)	EH50709 (UK Plug-EH Controller) EH50728 (UK Plug-Strix Controller)
Page	8	8	8
Power	220-240V, 50-60Hz	220-240V, 50-60Hz	220-240V, 50-60Hz
Wattage	800-950W	800-950W	800-950W
Capacity	1 Litre	1 Litre	1 Litre
DUAL SAFE	Yes	Yes	Yes
Material	High Grade SS304 Stainless Steel Body & Heat Plate	High Grade SS304 Stainless Steel Body & Heat Plate	High Grade SS304 Stainless Steel Body & Heat Plate
Overall Height	209mm	209mm	209mm
Top Diameter	90mm	90mm	90mm
Base Diameter	143mm	143mm	143mm
Weight	790g	790g	790g
Certification			
Mark/Warranty	12pcs - 52.5 x 39.5 x 43.0cm 12.5kg 0.089CBM	12pcs - 53.0 x 40.0 x 43.0cm 12.37kg 0.091CBM	12pcs - 53.0 x 40.0 x 43.0cm 12.37kg 0.091CBM
Packaging Details			
Barcodes	EH50633 (EU Plug-EH Controller)  EH50637 (EU Plug-Strix Controller)  EH50636 (UK Plug-Strix Controller)  	EH50705 (EU Plug-EH Controller)  EH50729 (EU Plug-Strix Controller)  	EH50709 (UK Plug-EH Controller)  EH50728 (UK Plug-Strix Controller)  



Model	Banbury	Guildford Black	Guildford White
Art No	EH50840 (EU Plug-EH Controller) EH50839 (UK Plug-EH Controller)	EH50740 (EU Plug-EH Controller) EH50739 (UK Plug-Strix Controller)	EH50743 (EU Plug-EH Controller) EH50742 (UK Plug-EH Controller)
Page	9	10	10
Power	220-240V, 50-60Hz	220-240V, 50-60Hz	220-240V, 50-60Hz
Wattage	800W	870-1035W	870-1035W
Capacity	0.8 Litre	0.8 Litre	0.8 Litre
DUAL SAFE	Yes	No	No
Material	High Grade SS304 Stainless Steel Body & Heat Plate	Plastic Body	Plastic Body
Overall Height	200mm	180mm	180mm
Top Diameter	111.5mm	90mm	90mm
Base Diameter	130mm	139mm	139mm
Weight	750g	605g	605g
Certification			
Mark/Warranty	12pcs - 45 x 35 x 39.8cm 11.2kg 0.063CBM	12pcs - 46.5 x 36.5 x 35cm 9.2kg 0.059CBM	12pcs - 46.5 x 36.5 x 35cm 9.2kg 0.059CBM
Packaging Detail			
Barcodes	EH50840 (EU Plug-EH Controller)  EH50839 (UK Plug-EH Controller)  	EH50740 (EU Plug-EH Controller)  EH50739 (UK Plug-Strix Controller)  	EH50743 (EU Plug-EH Controller)  EH50742 (UK Plug-EH Controller)  

# SPECIFICATIONS - WELCOME TRAYS BAMBOO



Model	Fenland Espresso Tray	Fenland Condiment Box	Winford - Black	Amesbury - Black
Art No	EH50820	EH50821	EH50756	EH50813
Page	14	14	15	16
Material	First Grade Bamboo	First Grade Bamboo	First Grade Bamboo	First Grade Bamboo
Cert Food Grade	Yes	Yes	Yes	Yes
Overall Length	50cm	21cm	37.0cm	39cm
Overall Width	40cm	19cm	35.0cm	31.5cm
Height	4cm	7cm	8.8cm	7.5cm
Weight	1800g	800g	3965g	2640g
Certification Mark/Warranty				
Packaging Details	5pcs- 52.5 x 43.5 x 32cm 11.20kg 0.0730CBM	10pcs- 43.5 x 43 x 25.2cm 9.05kg 0.0471CBM	5pcs- 49.6 x 39 x 37.5cm 18.0kg 0.0725CBM	5pcs - 43.8 x 41.5 x 35.2cm 15.0kg 0.0640CBM
Barcodes	EH50820 	EH50821 	EH50756 	EH50813 

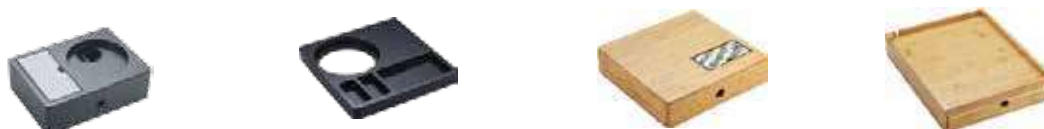

Model	Cambourne Plus - Black	Tongwell - Black	Winford - Natural	Amesbury - Natural
Art No	EH50688	EH50467	EH50836	EH50833
Page	17	18	19	20
Material	First Grade Bamboo	First Grade Bamboo	First Grade Bamboo	First Grade Bamboo
Cert Food Grade	Yes	Yes	Yes	Yes
Overall Length	27.0cm	26cm	37.0cm	39cm
Overall Width	19.4cm	26cm	35.0cm	31.5cm
Height	8.5cm	3cm	8.8cm	7.5cm
Weight	1450g	850g	4060g	2640g
Certification Mark/Warranty				
Packaging Details	12pcs- 57.6 x 28.7 x 42.2cm 17.10kg 0.0698CBM	12pcs- 49 x 28 x 28.2cm 11.81kg 0.039CBM	5pcs- 52.5 x 39.5 x 37.9cm 22.1kg 0.0786CBM	5pcs- 43.8 x 41.5 x 35.2cm 15kg 0.0640CBM
Barcodes	EH50688 	EH50467 	EH50836 	EH50833 



Model	Cambourne Plus - Natural	Tongwell - Natural	Tongwell - Mahogany
Art No	EH50834	EH50289	EH50468
Page	21	22	22
Material	First Grade Bamboo	First Grade Bamboo	First Grade Bamboo
Cert Food Grade	Yes	Yes	Yes
Overall Length	27.0cm	26cm	26cm
Overall Width	19.4cm	26cm	26cm
Height	8.5cm	3cm	3cm
Weight	1450g	850g	850g
Certification Mark/Warranty			
Packaging Details	12pcs- 57.6 x 28.7 x 42.2cm 20.5kg 0.0698CBM	12pcs- 49 x 28 x 28.2cm 11.81kg 0.039CBM	12pcs- 49 x 28 x 28.2cm 11.81kg 0.039CBM
Barcodes	EH50834 	EH50289 	EH50468 

# SPECIFICATIONS - WELCOME TRAYS ABS SERIES



Model	Heywood ABS - Main Tray Black Matt	Heywood Slate - Service Tray Black Matt	Heywood Slate - Amenity Holder Black Matt
Art No	EH50822	EH50823	EH50824
Page	23	23	23
Material	ABS	ABS	ABS
Cert Food Grade	Yes	Yes	Yes
Overall Length	35.8cm	23.5cm	14.5cm
Overall Width	25.8cm	11cm	7.5cm
Height	1cm	1cm	4cm
Weight	285g	75g	85g
Certification			
Mark/Warranty			
Packaging Details	24pcs- 37.6 x 28.5 x 31.2cm 7.97kg 0.0334CBM	24pcs- 30 x 26 x 13cm 2.6kg 0.0101CBM	24pcs- 35 x 20 x 17.7cm 2.9kg 0.0123CBM
Barcodes	EH50822 	EH50823 	EH50824 



Model	Heywood Slate - Compact Tray. Black Matt	Heywood Slate - Amenity Organiser. Black Matt	Walton
Art No	EH50825	EH50826	EH50175
Page	25	25	26
Material	ABS	ABS	ABS
Cert Food Grade	Yes	Yes	Yes
Overall Length	33cm	12.5cm	46cm
Overall Width	16cm	8cm	22.5cm
Height	1cm	5.8cm	3.5cm
Weight	170g	120g	738g
Certification			
Mark/Warranty			
Packaging Details	24pcs- 34.5 x 18.5 x 31cm 4.8kg 0.0198CBM	24pcs- 43.2 x 27.5 x 15.1cm 3.8kg 0.0179CBM	12pcs- 55 x 25 x 49cm 11.37kg 0.067CBM
Barcodes	EH50825 	EH50826 	EH50175 



Model	Andover	Mere
Art No	EH50873	EH50826
Page	29	30
Material	ABS	ABS
Cert Food Grade	Yes	Yes
Overall Length	36.3cm	15cm
Overall Width	24.1cm	15cm
Height	3cm	
Weight	400g	26g
Certification		
Mark/Warranty		
Packaging Details	48pcs- 84 x 38.2 x 50.4cm 22.9kg 0.161CBM	108pcs- 47 x 31.5 x 30cm 4.28kg 0.0444CBM
Barcodes	EH50873 	EH50913 

# SPECIFICATIONS - WELCOME TRAYS MELAMINE



Model	Halstead Black (Matt)	Halstead White (Matt)
Art No	EH50678	EH50679
Page	27	27
Material	Melamine	Melamine
Cert Food Grade	Yes	Yes
Overall Length	26.20cm	26.20cm
Overall Width	26.20cm	26.20cm
Height	3cm	3cm
Weight	610g	610g
Certification		
Mark/Warranty		
Packaging Details	12pcs- 41 x 29 x 28cm 9.05kg 0.033CBM	12pcs- 41 x 29 x 28cm 9.05kg 0.033CBM
Barcodes	EH50678  9 557726 506787	EH50679  9 557726 506794

# SPECIFICATIONS - HAIRDRYERS



Model	Thames 1875W	Harrow Black Matt 1600W
Art No	EH50844 (EU Plug) EH50845 (UK Plug)	EH50777 (EU Plug) EH50778 (UK Plug)
Page	31	33
Power	220-240V, 50-60Hz	220-240V, 50-60Hz
Wattage	1800-2200W	1400-1600W
DUAL SAFE	Yes	Yes
Heat Setting	Two	Two
Removable Filter	Yes	Yes
Steam Mesh Blade Cover	Yes	Yes
On /Off Press Switch	Yes	Yes
Thermostat Overheat Protection	Yes	Yes
Material	Polypropylene Ceramic Ionic	Plastic with luxury matt finish
Cable length	Heavy Duty Coil Cable 350cm	200cm
Colour	Black	Black
Dimensions	240 x 85 x 280mm	140 x 77 x 231mm
Weight	615g	390g
Certification		
Mark/ Warranty		
Packaging Details	10pcs - 48.5 x 41.5 x 30cm 8.37kg 0.06CBM	20pcs - 47 x 27.5 x 45cm 11.50kg 0.058CBM
Barcodes	EH50844 (EU Plug)  9 557726 508446 EH50845 (UK Plug)  9 557726 508453	EH50777 (EU Plug)  9 557726 507777 EH50778 (UK Plug)  9 557726 507784



# SPECIFICATIONS - HAIRDRYERS



Model	Emsworth 1875W	Ashford 1600W
Art No	EH50846 (EU Plug) EH50847 (UK Plug)	EH50918 (EU Plug) EH50919 (UK Plug)
Page	34	35
Power	220-240V, 50-60Hz	220-240V, 50-60Hz
Wattage	1875W DC Motor	1600W BLDC Motor
DUAL SAFE	Yes	Yes
Heat Setting	Three	Three
Removable Filter	Yes	Yes
Steam Mesh Blade Cover	Yes	Yes
On /Off Press Switch	Yes	Yes
Thermostat Overheat Protection	Yes	Yes
Material	Polypropylene Ceramic Ionic	Ionic - Negative Ions
Cable length	Coil Cable 300cm	
Colour	Black	Matt Grey
Dimensions	145 x 75 x 260mm	123 x 270 x 74mm
Weight	675g	590g
Certification		
Mark/ Warranty		
Packaging Details	10pcs- 52 x 44 x 30cm 7.6kg 0.0686CBM	10pcs- 34.8 x 34.4 x 44.7cm 9.5kg 0.0535CBM
Barcodes	<p>EH50846 (EU Plug)</p> <p>9 557726 508460</p> <p>EH50847 (UK Plug)</p> <p>9 557726 508477</p>	<p>EH50918 (EU Plug)</p> <p>9 557726 509184</p> <p>EH50919 (UK Plug)</p> <p>9 557726 509191</p>

Model	Devizes - Hairdryer Holder
Art No	EH50866
Page	36
Material	ABS
Anti Theft	Yes
Suit Hard Wired Installation	Yes
Easy Mounting	Yes
Colour	Matt Black
Dimensions	90 x 90 x 78.5mm
Weight	56g
Packaging Details	200pcs- 95 x 51 x 46cm 30kg 0.22287CBM
Barcodes	<p>EH50866</p> <p>9 557726 508666</p>



Model	Mursley - Black	Mursley - White	Mursley - Chrome/Black
Art No	EH50608	EH50609	EH50440
Page	37	37	37
Material	Silicon Inner Black Rubber - Outer	Silicon - Inner White Rubber - Outer	Silicon - Inner Plastic Chrome Rubber - Outer
Anti Theft	Yes	Yes	Yes
Suit Hard Wired Installation	Yes	Yes	Yes
Easy Mounting	Yes	Yes	Yes
Dimensions	93 x 74 x 50mm	93 x 74 x 50mm	93 x 74 x 50mm
Weight	45g	45g	50g
Packaging Details	200pcs- 90 x 32 x 45cm 16.4kg 0.13CBM	200pcs- 90 x 32 x 45cm 16.4kg 0.13CBM	200pcs- 90 x 32 x 45cm 16.63kg 0.13CBM
Barcodes	<p>EH50608</p> <p>9 557726 506084</p>	<p>EH50609</p> <p>9 557726 506091</p>	<p>EH50440</p> <p>9 557726 504400</p>

Model	Lathbury Hairdryer Bag
Art No	EH50357
Page	38
Material	Soft Velvet Silver Thread Embroidery Strong Black PP Drawstring
Colour	Black
Dimensions	400 x 300mm
Weight	66g
Packaging Details	200pcs- 44 x 34.5 x 55cm 14kg 0.084CBM
Barcodes	<p>EH50357</p> <p>9 557726 503571</p>

# SPECIFICATIONS - IRONS



Model	Croft Deluxe - Steam Iron	Hertford Black - Steam Iron
Art No	EH50785 ( EU Plug ) EH50786 ( UK Plug )	EH50501 (EU Plug) EH50502 (UK Plug)
Page	39	41
Power	220-240V, 50-60Hz	220-240V, 50-60Hz
Wattage	2000W	1600W
DUAL SAFE	Yes	Yes
Water Tank Capacity	300ml	250ml
Eco Auto Off Function	Yes	Yes
Anti Drip	Yes	Yes
Thermo Weld Technology	Yes	Yes
5min Auto Off Function	Yes	Yes
Sole Plate Material	Ceramic	Non-Stick
Cable	Heavy Duty 300cm	Heavy Duty 250cm
Colour	Black/Grey	Black/Grey
Plate size	228 x 123mm	206 x 113mm
Product size	290 x 123 x 151mm	266 x 120 x 140mm
Weight	1180g	982g
Certification		
Mark/Warranty	10pcs - 66.4 x 31.9 x 32.5cm 14kg 0.069CBM	10pcs - 62.5 x 30.5 x 32.5cm 11.70kg 0.062CBM
Packaging Details		
Barcodes	<p>EH50785 ( EU Plug )</p> <p>9 557726 507852</p> <p>EH50786 ( UK Plug )</p> <p>9 557726 507869</p>	<p>EH50501 (EU Plug)</p> <p>9 557726 505018</p> <p>EH50502 (UK Plug)</p> <p>9 557726 505025</p>



Model	Hertford White - Steam Iron	Havant Deluxe - Steam Iron
Art No	EH50546 (EU Plug) EH50547 (UK Plug)	EH50515 (UK Plug)
Page	41	41
Power	220-240V, 50-60Hz	220-240V, 50-60Hz
Wattage	1600W	1600W
DUAL SAFE	Yes	Yes
Water Tank Capacity	250ml	250ml
Eco Auto Off Function	Yes	Yes
Anti Drip	Yes	Yes
Thermo Weld Technology	Yes	Yes
5min Auto Off Function	Yes	Yes
Sole Plate Material	Non-Stick	Non-Stick
Cable	Heavy Duty 250cm	Heavy Duty 190cm
Colour	White/Grey	White/Grey
Plate size	206 x 113mm	206 x 113mm
Product size	266 x 120 x 140mm	266 x 120 x 140mm
Weight	982g	982g
Certification		
Mark/Warranty	10pcs - 62.5 x 30.5 x 32.5cm 11.70kg 0.062CBM	10pcs - 62.5 x 30.0 x 32.5cm 11.5kg 0.0609CBM
Packaging Details		
Barcodes	<p>EH50546 (EU Plug)</p> <p>9 557726 505469</p> <p>EH50547 (UK Plug)</p> <p>9 557726 505476</p>	<p>EH50515 (UK Plug)</p> <p>9 557726 505155</p>

# SPECIFICATIONS - IRONS



Model	Yardley - Dry Iron	Ampthill 2 in 1 Steamer & Iron	Cheshunt 2 in 1 Digital Steamer & Iron
Art No	EH50548 (EU Plug) EH50549 (UK Plug)	EH50853 (EU Plug) EH50854 (UK Plug)	EH50851 (EU Plug) EH50852 (UK Plug)
Page	42	43	44
Power	220-240V, 50-60Hz	220-240V, 50-60Hz	220-240V, 50-60Hz
Wattage	1200W	1650-1950W	1400-1800W
DUAL SAFE	Yes	Yes	Yes
Water Tank Capacity	No	170ml	180ml
Eco Auto Off Function	Yes	Yes	Yes
Anti Drip	Yes	No	No
Thermo Weld Technology	Yes	Yes	Yes
5min Auto Off Function	Yes	Yes	Yes
Sole Plate Material	Non-Stick	Double Layer Ceramic	Double Layer Ceramic
Cable	Heavy Duty 250cm	Heavy Duty 250cm	Heavy Duty 250cm
Colour	Black/Grey	Black/Grey	Black/Grey
Plate size	200 x 110mm	133 x 88mm	143 x 97mm
Product size	257 x 114 x 126mm	413 x 92 x 143mm	362 x 97 x 180mm
Weight	745g	900g	950g
Certification			
Mark/Warranty			
Packaging Details	10pcs - 59.5 x 29 x 31cm 9.22kg 0.054CBM	10pcs - 57.5 x 45.0 x 31.7cm 13.05kg 0.082CBM	10pcs - 60.0 x 41.0 x 47.2cm 14.78kg 0.116CBM
Barcodes	  	  	  



Model	Steamer Bag
Art No	EH50920
Page	45
Material	Heat Resistant Cotton Silver Thread Embroidery Strong PP Drawstring
Colour	Black
Dimensions	460 x 252mm
Weight	35g
Packaging Details	200pcs
Barcodes	 EH50920 9 557726 509207

# SPECIFICATIONS - TOUGH IRONING BOARDS



Model	Sherington - Ironing Board Full Size	Moulton - Ironing Board Compact Size	Rothwell - Ironing Board Compact Size with Fixed Metal Rest
Art No	EH50379	EH50380	EH50383
Page	46	47	47
Material	Metal	Metal	Metal
Metal Mesh Top	Yes	Yes	Yes
Rugged Tube	Yes	Yes	Yes
Frame Legs 38mm/28mm	Yes	Yes	Yes
Suit Hard Wired	Yes	Yes	Yes
Cover Grey Metallic Fabric Colour	Yes	Yes	Yes
	Silver Grey Frame Grey Fabric Colour	Silver Grey Frame Grey Fabric Colour	Silver Grey Frame Grey Fabric Colour
Underlay Plus Foam	Yes	Yes	Yes
Smooth Binding Edges	Yes	Yes	Yes
Pre fitted System to Attached Holders	Yes	Yes	No
Fixed Metal Rest	No	No	Yes
Warranty			
Dimensions	109 x 38cm	97 x 33cm	116 x 33cm
Height	87cm	76cm	76cm
Folded Size	133 x 38 x 7cm	117 x 33 x 7cm	128 x 33 x 7cm
Packaging Details	4pcs- 135.5 x 35 x 42.5cm 23.15kg 0.202CBM	4pcs- 120.5 x 36 x 37.5cm 20.50kg 0.163CBM	4pcs- 131.5 x 35.5 x 38cm 21.55kg 0.177CBM
Barcodes	EH50379  9 557726 503793	EH50380  9 557726 503809	EH50383  9 557726 503830



Model	Stanion - Iron Board Cover Full Size	Warkton - Iron Board Cover Compact Size
Art No	EH50388	EH50387
Page	47	47
Material	100% Cotton, Coated Aluminium Surface, Foam & Polyester Underlay	100% Cotton, Coated Aluminium Surface, Foam & Polyester Underlay
Colour	Charcoal Grey	Charcoal Grey
Warranty		
Dimensions	109 x 38cm	97 x 33cm
Packaging Details	20pcs- 53 x 32 x 51.5cm 6.0kg 0.087CBM	20pcs- 53.5 x 33 x 41cm 5.5kg 0.072CBM
Barcodes	EH50388  9 557726 503885	EH50387  9 557726 503878



# SPECIFICATIONS - IRONING CENTRES SAFETY & STORAGE



Model	Kingsmead	Bromham
Art No	EH50428 (EU Plug) EH50429 (UK Plug)	EH50442 (EU Plug) EH50441 (UK Plug)
Page	49	49
<b>Inclusions</b>		
Ironing Board/Art No	Sherington (Full Size) / EH50379	Sherington (Full Size) / EH50379
Iron / Art No	Hertford Steam Iron 1600W / EH50501 (EU Plug) EH50502 (UK Plug)	Yardley Dry Iron 1200W / EH50548 (EU Plug) EH50549 (UK Plug)
Iron Holder/Art No	Chorley / EH50518	Deene / EH50398
<b>Dimensions</b>		
Board	109 x 38 x 87cm	109 x 38 x 87cm
Folded size without holder	133 x 38 x 7cm	133 x 38 x 7cm
Folded size with holder	144 x 38 x 7cm	144 x 38 x 7cm
<b>Packaging Details</b>		
Ironing Board	4pcs-135.5 x 35 x 42.5cm 23.15kg 0.202CBM	4pcs-135.5 x 35 x 42.5cm 23.15kg 0.202CBM
Hertford 1600W	10pcs-62.5 x 30.5 x 32.5cm 11.70kg 0.062CBM	
Iron Yardley 1200W		10pcs-59.5 x 29 x 31cm 9.22kg 0.053CBM
Holder Chorley	12pcs-87.5 x 41.7 x 33.7cm 15kg 0.123CBM	
Holder Deene		12pcs-42 x 43 x 54.5cm 14.60kg 0.098CBM
Warranty		
Barcodes	EH50428 EH50429 	EH50442 EH50441 



Model	Stagsden	Elstow
Art No	EH50431 (EU Plug) EH50430 (UK Plug)	EH50444 (EU Plug) EH50443 (UK Plug)
Page	49	49
<b>Inclusions</b>		
Ironing Board/Art No	Moulton (Compact Size) / EH50380	Moulton (Compact Size) / EH50380
Iron / Art No	Hertford Steam Iron 1600W / EH50501 (EU Plug) EH50502 (UK Plug)	Yardley Dry Iron 1200W / EH50548 (EU Plug) EH50549 (UK Plug)
Iron Holder/Art No	Chorley / EH50518	Deene / EH50398
<b>Dimensions</b>		
Board	97 x 33 x 76cm	97 x 33 x 76cm
Folded size without holder	117 x 33 x 7cm	117 x 33 x 7cm
Folded size with holder	128 x 33 x 7cm	128 x 33 x 7cm
<b>Packaging Details</b>		
Ironing Board	4pcs-120.5 x 36 x 37.5cm 20.5kg 0.163CBM	4pcs-120.5 x 36 x 37.5cm 20.5kg 0.163CBM
Hertford 1600W	10pcs-62.5 x 30.5 x 32.5cm 11.70kg 0.062CBM	
Iron Yardley 1200W		10pcs-59.5 x 29 x 31cm 9.22kg 0.053CBM
Holder Chorley	12pcs-87.5 x 41.7 x 33.7cm 15kg 0.123CBM	
Holder Deene		12pcs-42 x 43 x 54.5cm 14.60kg 0.098CBM
Warranty		
Barcodes	EH50431 EH50430 	EH50444 EH50443 

# SPECIFICATIONS - IRONING CENTRES SAFETY & STORAGE



Model	Stroud - Iron Holder	Stroud - U Hook	Swivel Holder Bracket with Anti Theft Cable Lock	Somerton - Iron Holder
Art No	EH50558	EH50563	EH50562	EH50507
Page	50	50	50	51
Material	Steel Double Non Slip Rubberized Protective Coating Finish	Steel	Steel	Soft Coated Protective Quality Steel Frame
Colour	Grey	Grey	Grey	Grey
Certification				
Mark/Warranty				
Dimensions	35.6 x 13.5 x 13cm	20.3 x 10.5 x 6.5cm	8.3 x 6 x 5.2cm	35 x 13.5 x 13cm
Weight	0.635kg	0.140kg	0.274kg	0.60kg
Packaging	12pcs- 60.7 x 43.4 x 36.9cm	100pcs- 67 x 27.8 x 24.5cm	100pcs- 52.5 x 34.5 x 15cm	10set- 90.7 x 28.0 x 30.0cm
Details	9.74kg 0.0972CBM	14kg 0.046CBM	30.4kg 0.0272CBM	6.45kg 0.0762CBM
Barcodes	EH50558 	EH50563 	EH50562 	EH50507 



Model	Somerton - J Hook	Oakham - Safety Grip Iron Store	Crawley - Universal Steamer Holder with Anti-Theft	Sandhurst - Open Rail Hook
Art No	EH50708	EH50814	EH50911	EH50556
Page	51	52	53	54
Material	Soft Coated Protective Quality Steel Frame	Heat-resistant PA Plate	Steel Double Non Slip Rubberized Protective Coating Finish	Steel- Soft Touch Finish
Colour	Grey	Grey	Black	Grey
Certification				
Mark/Warranty				
Dimensions	22 x 10.5 x 5.8cm	24.7 x 15.9 x 2.4cm	29.0 x 12 x 12.3cm	6.6 x 6.2 x 12.6cm
Weight	0.135kg	0.176kg	0.350kg	0.820kg
Packaging	50pcs- 58.0 x 40.8 x 24.0cm	20set- 33.8 x 26.5 x 29.5cm	30pcs- 60 x 46 x 38cm	100pcs- 47 x 20 x 30cm
Details	9.80kg 0.0568CBM	5.64kg 0.528CBM	13.5kg 0.105CBM	10.0kg 0.0282CBM
Barcodes	EH50708 	EH50814 	EH50911 	EH50556 



Model	Sandhurst - Open Rail Hook	Hyde - Wall Bracket
Art No	EH50556	EH50508
Page	54	55
Material	Steel- Soft Touch Finish	Heavy Duty Carbon Steel Double Silver Powder Coated Finish
Colour	Grey	Grey
Certification		
Mark/Warranty		
Dimensions	6.6 x 6.2 x 12.6cm	170 x 74mm
Weight	0.820kg	0.160kg
Packaging	100pcs- 47 x 20 x 30cm	100pcs- 70 x 19.5 x 17.5cm
Details	10.0kg 0.0282CBM	18kg 0.024CBM
Barcodes	EH50556 	EH50508 

# SPECIFICATIONS - ACCESSORIES & ROOM ESSENTIALS



Model	Bodmin - Multi-Function Alarm Clock with Wireless Charging & Speaker	Woburn - Push Power Digital Bathroom Scale	Woburn - Push Power Digital Bathroom Scale
Art No	EH50768-EU Plug/EH50769-UK Plug	EH50755	EH50753
Page	65	68	68
Power	AC 110 - 240V, 50-60Hz	PUSH POWER Button	PUSH POWER Button
Wattage	10W	Battery Free	Battery Free
Battery	2 x 1.5V AAA Batteries (NOT INCLUDED)	5-180kg	5-180kg
Colour	Black	Units in KG & LBS	Units in KG & LBS
Material	ABS	Black	White
Dimensions	128 x 102 x 77mm	8mm Toughened Safety Glass	8mm Toughened Safety Glass
Weight	0.45kg	310 x 310 x 30mm	310 x 310 x 30mm
Certification			
Mark/Warranty			
Packaging	18pcs- 43.2 x 36.8 x 36cm	6pcs- 37.5 x 34.5 x 34.5cm	6pcs- 37.5 x 34.5 x 34.5cm
Details	11.8kg 0.0572CBM	14.50kg 0.0446CBM	14.50kg 0.0446CBM
Barcodes	<div style="display: flex; justify-content: space-around;"> <div style="text-align: center;">                       EH50768 (EU Plug)                      9 557726 507685                 </div> <div style="text-align: center;">                       EH50769 (UK Plug)                      9 557726 507692                 </div> </div>	 EH50755 9 557726 507555	 EH50753 9 557726 507531



Model	Whitehill Scale	Wilton Scale - Black	Wilton Scale - Natural
Art No	EH50806	EH50789	EH50835
Page	70	71	72
Power	2xAAA Battery Included	3xAAA Battery Included	3xAAA Battery Included
Capacity	180kg	5-180kg	5-180kg
Units	KG-LB-ST	KG-LB-ST	KG-LB-ST
Colour	-	Black	Natural
Material	Stainless Steel	First Grade Bamboo	First Grade Bamboo
Dimensions	300 x 300 x 22mm SS304+6mm Tempered Glass	300 x 300 x 31mm 15mm Real Bamboo	300 x 300 x 31mm 15mm Real Bamboo
Weight	1690g	1105g	1105g
Certification			
Mark/Warranty			
Packaging	6pcs - 33 x 24 x 33.5cm	6pcs - 33 x 28.5 x 33.5cm	6pcs - 33 x 28.5 x 33.5cm
Details	11.2kg 0.0265CBM	9.2kg 0.0315CBM	9.2kg 0.0315CBM
Barcodes	 EH50806 9 557726 508064	 EH50789 9 557726 507890	 EH50835 9 557726 508354

# SPECIFICATIONS - ACCESSORIES & ROOM ESSENTIALS



Model	Fairford Digital Bathroom Scale	Ashton Digital Bathroom Scale
Art No	EH50928	EH50358
Page	73	74
Power	2xCR2032 Lithium Iron Battery Included	2xAAA Battery Included
Capacity	5-180kg	180kg
Units	KG-LB-ST	KG-LB
Colour	White	Black
Material	Non Slip Tempered Glass Platform	Tempered Glass Platform
Dimensions	300 x 300 x 22mm 8mm Tempered Glass	300 x 300 x 24mm 8mm Tempered Glass
Weight	1.985kg	1.95kg
Certification Mark/Warranty		
Packaging Details	4pcs- 35 x 20.5 x 35.5cm 9.3kg 0.026CBM	6pcs- 33.8 x 31.4 x 34.9cm 13.20kg 0.037CBM
Barcodes	<p>EH50928</p> <p>9 557726 509283</p>	<p>EH50358</p> <p>9 557726 503588</p>



Model	Alton USB Rechargeable Torchlight
Art No	EH50838
Page	67
Power	5V
Battery	Built in 1200mAh 18650 li-ion
Wattage	10W
Lumen	1000 lm
Beam Distance	100m
Light Colour	White Light
Material	ABS
Charging Port	Micro USB Port
Charging Time	2 Hours
Water Proof Rate	IPX4
Dimensions	13.7 x 3.6 x 2.7cm
Weight	98g
Certification Mark/Warranty	
Packaging Details	100pcs - 52 x 38.5 x 21cm 15kg 0.0420CBM
Barcodes	<p>EH50838</p> <p>9 557726 508385</p>





Model	1600W Cylindrical Hairdryer
Art No	SA90034 (UK) SA90035 (EU)
Page	75
Power	220-240V, 50-60Hz
Wattage	1400-1800W
DUAL SAFE	NO
Heat Setting	2
Removable Filter	YES
Steam Mesh Blade Cover	YES
On /Off Press Switch	NO
Thermostat Overheat Protection	YES
Material	Plastic with Luxury Matt Finish
Cable length	STRAIGHT CABLE 1.8M
Colour	BLACK
Dimensions	17.7 x 23.5 x 7.5cm
Weight	530g
Certification Mark//Warranty	
Packaging Details	20pcs - 31.5 x 44.5 x 52cm 12kg 0.0729CBM
Barcodes	<div style="display: flex; flex-direction: column; align-items: center;"> <div style="display: flex; justify-content: space-between; width: 100%;"> <span>SA90034 (UK Plug)</span> </div> <div style="display: flex; justify-content: space-between; width: 100%;"> <span>SA90035 (EU Plug)</span> </div> </div>

Model	Emergency Torchlight INSTANT-ON
Art No	SA90005 (Battery) SA90006 (UK Charger) SA90007 (EU Charger)
Page	76
Power	AC100V-250V, 50-60Hz
Battery	x3 1.5V AA Alkaline or Lithium Batteries (NOT INCLUDED)
Wattage	3.9W - hours
Lumen	120 lumen
Beam Angle	180°
Light Colour	White Light
Material	Aluminium and ABS
Holder Dimension	175mm x 60 mm
Torchlight Dimension	178mm x 44 mm
Weight	280g
Certification	
Mark/Warranty	40pcs - 43 x 29 x 36cm
Packaging Details	14.0kg 0.045CBM
Barcodes	<div style="display: flex; flex-direction: column; align-items: center;"> <div style="display: flex; justify-content: space-around; width: 100%;"> <div style="text-align: center;"> <span>SA90005 (Battery)</span> </div> <div style="text-align: center;"> <span>SA90007 (EU Plug)</span> </div> </div> <div style="text-align: center; margin-top: 10px;"> <span>SA90006 (UK Plug)</span> </div> </div>



## ***INTELLECTUAL PROPERTY***

*Patents & Registered Designs*



**TOUGH BOARD** - Rugged & Durable; We have combined a rugged frame with heavy duty metal components and robotic welds to withstand guests' tough use.



**DUAL SAFE** - an organic, thermo-sensitive material, remarkably sensitive to abnormally high temperatures. Upon sensing critical heat levels, DUAL SAFE activates and the electrical current will be interrupted immediately and permanently.



**WATER TANK TECHNOLOGY** - Special anti-fracture water tank welding technique ensures a permanent seal to prevent water leakage.

# EMBERTON™

[www.emberton.com](http://www.emberton.com)  
[info@emberton.com](mailto:info@emberton.com)